

(12) **UK Patent Application** (19) **GB** (11) **2 325 537** (13) **A**

(43) Date of A Publication 25.11.1998

(21) Application No **9805687.2**

(22) Date of Filing **17.03.1998**

(30) Priority Data

(31) **08828709** (32) **31.03.1997** (33) **US**

(71) Applicant(s)

**Microsoft Corporation**  
**(Incorporated in USA - Washington)**  
**One Microsoft Way, Redmond, WA 98052-6399,**  
**United States of America**

(72) Inventor(s)

**James O Robarts**  
**David S Byrne**  
**Steve Fluegel**  
**Gabe Newell**  
**Dan Newell**  
**Kenneth Abbott**

(51) INT CL<sup>6</sup>

**H04N 7/088 , G06F 17/30**

(52) UK CL (Edition P )

**G4A AUDB**  
**H4F FBB FD22 FD24**  
**U1S S2206**

(56) Documents Cited

**EP 0758833 A2 EP 0705036 A2 WO 97/46011 A1**  
**WO 97/02702 A2 WO 94/14284 A1 US 5606691 A**  
**US 5223924 A**

(58) Field of Search

**UK CL (Edition P ) G4A AUDB , H4F FBB**  
**INT CL<sup>6</sup> G06F 17/30 , H04N 7/088**  
**Online: WPI**

(74) Agent and/or Address for Service

**Withers & Rogers**  
**4 Dyer's Buildings, Holborn, LONDON, EC1N 2QP,**  
**United Kingdom**

(54) Abstract Title

**An electronic television programme guide**

(57) An electronic programme guide (EPG) database is interrogated to produce a list of programmes that may be of interest to a viewer. Queries may be composed by users or may be developed automatically by inspection of viewing habits or viewer profiles. Viewer profiles may be produced by interrogation of the viewer. User queries may be stored hierarchically and queries relating to different viewers may be merged. Queries may be allowed to run continually to uncover programmes of interest as they arise in the EPG. Queries may restrict selection of certain categories. A 10-key alphanumeric keypad may be used to enter query data. The EPG interprets the data from each key to mean any of the numbers or letters associated therewith and identifies all possible programmes and channels and networks. As the viewer continues to add letters or numbers, the list narrows dynamically until only a few choices remain. The EPG data may be transmitted with the TV signals and may contain links to Web pages.

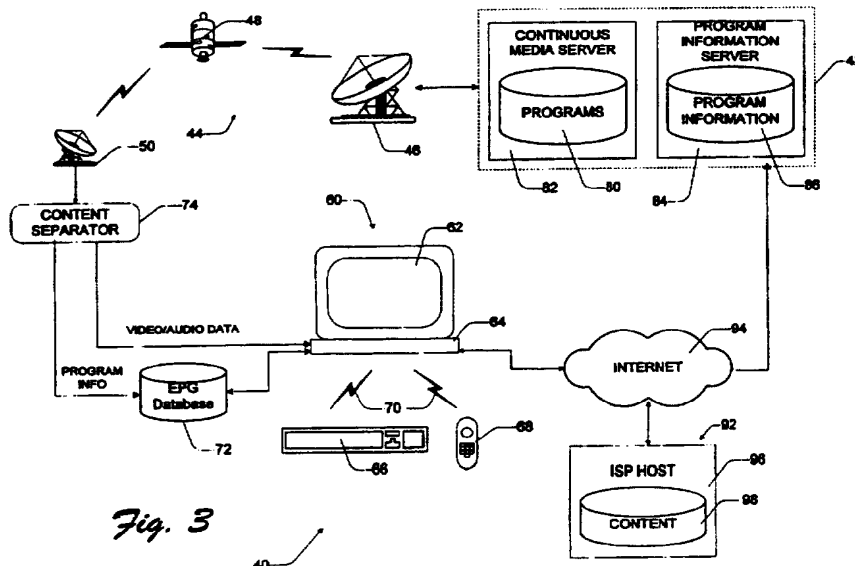

*Fig. 3*

Grid Log Station Titles Actors Category Movies Sports Custom Schedule

| Date          | Station | Title/Episode           | Duration |
|---------------|---------|-------------------------|----------|
| 12/15 8:00 am | CNBC    | This Morning's Business | 30 min   |
| 12/15 8:00 am | USA     | First Business          | 30 min   |
| 12/15 8:30 am | CNBC    | Money Wheel             | 3 hours  |
| .             | .       | .                       | .        |
| .             | .       | .                       | .        |
| .             | .       | .                       | .        |
| .             | .       | .                       | .        |
| .             | .       | .                       | .        |
| .             | .       | .                       | .        |
| .             | .       | .                       | .        |
| .             | .       | .                       | .        |

26

22

24

20

1/12

Fig. 1  
Prior Art

2/12

Search--Untitled

File

Stations

- AMC
- ARTS
- BET
- BRAVO
- CNBC
- CNN
- COM
- CRTV
- CSPAN
- CSPANIII
- DISN
- DSC
- EI
- ESPN
- FAM
- HBO
- HSC
- HTS
- LIFE
- MAX
- MTV
- NICK

Program Types

- Business
- Business: Business
- Business: Finance
- Business: Investment
- Childrens
- Childrens: Nature
- Childrens: Science
- Educational
- Educational: History
- Educational: Music
- Educational: Science
- Educational: Teach
- Game Show
- Health
- Health: Health
- Health: Parenting
- How To
- How To: Art
- How To: Cooking
- How To: Crafts
- How To: Games
- How To: Gardening

34

Date/Time Field

MPAA

G  
PG  
PG13  
R

Rating

.  
..  
...  
....

Help

Preview

Begin

Reset

Cancel

36

30

Fig. 2

Prior Art

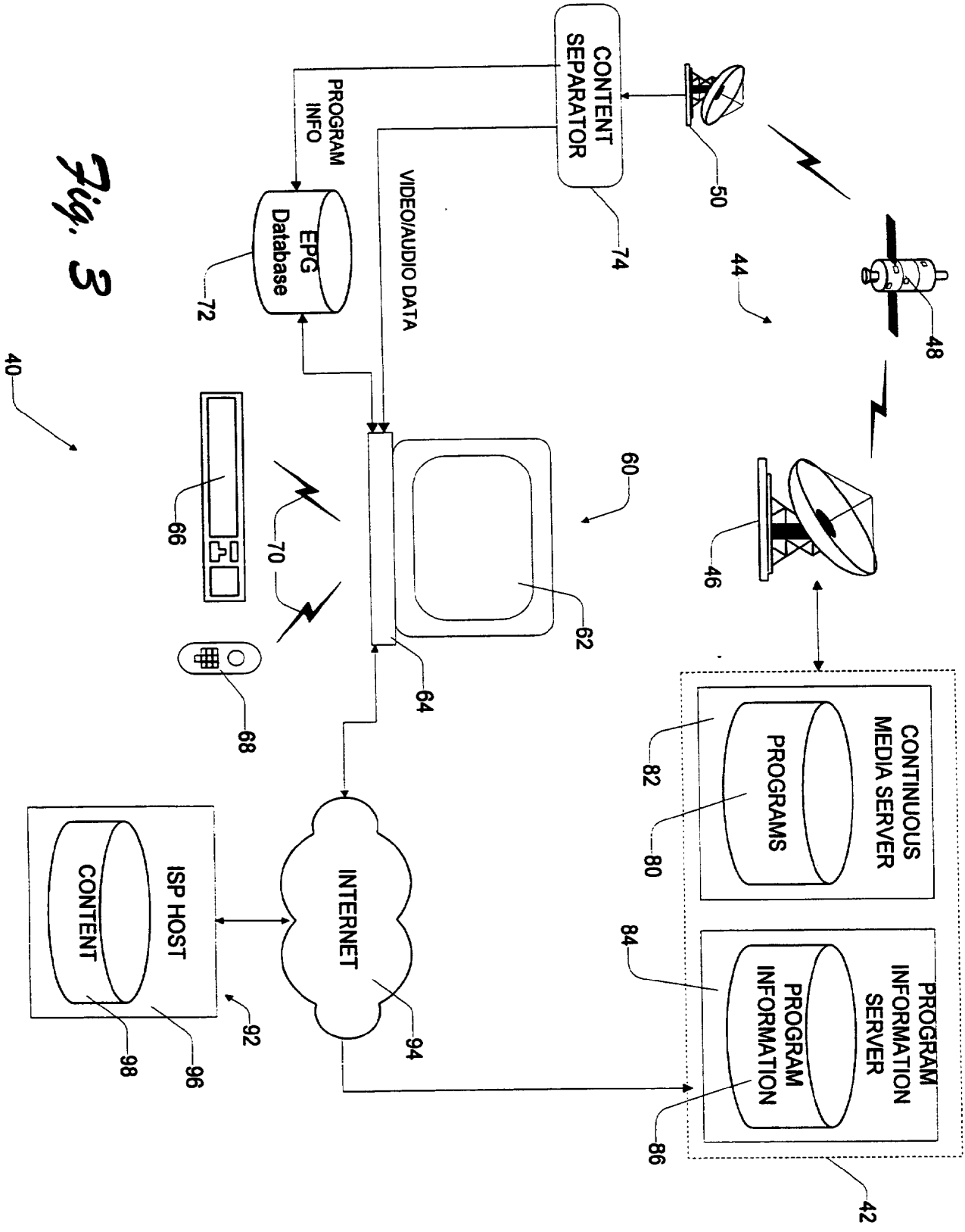

Fig. 3

40

4/12

| STORAGE POINTER | TITLE               | ACTOR     | CC  | STEREO | TIME             | NETWORK | SUPPLEMENTAL CONTENT   | DESCRIPTION                              |
|-----------------|---------------------|-----------|-----|--------|------------------|---------|--|--|
| PROG1           | MURDER, SHE WROTE   | LANDSBURY | YES | YES    | 8:00 PM THURSDAY | CBS     | CONTENT1   | "The Secret of Gila Junction" Jessica... |
| PROG2           | SEINFELD            | SEINFELD  | YES | YES    | 9:00 PM THURSDAY | NBC     | <a href="http://www.nbc.com/seinfeld.html">http://www.nbc.com/seinfeld.html</a>  | "The Friars Club" Jerry tries...         |
| PROG3           | STAR TREK NEXT GEN. | STEWART   | YES | YES    | 10:00 PM FRIDAY  | FOX     | <a href="http://www.fox.com/startrek.html">http://www.fox.com/startrek.html</a><br><a href="http://www.collections.com/trakecollections.html">http://www.collections.com/trakecollections.html</a> | "Delta Vega" Picard is faced....         |

90

88

Fig. 4

5/12

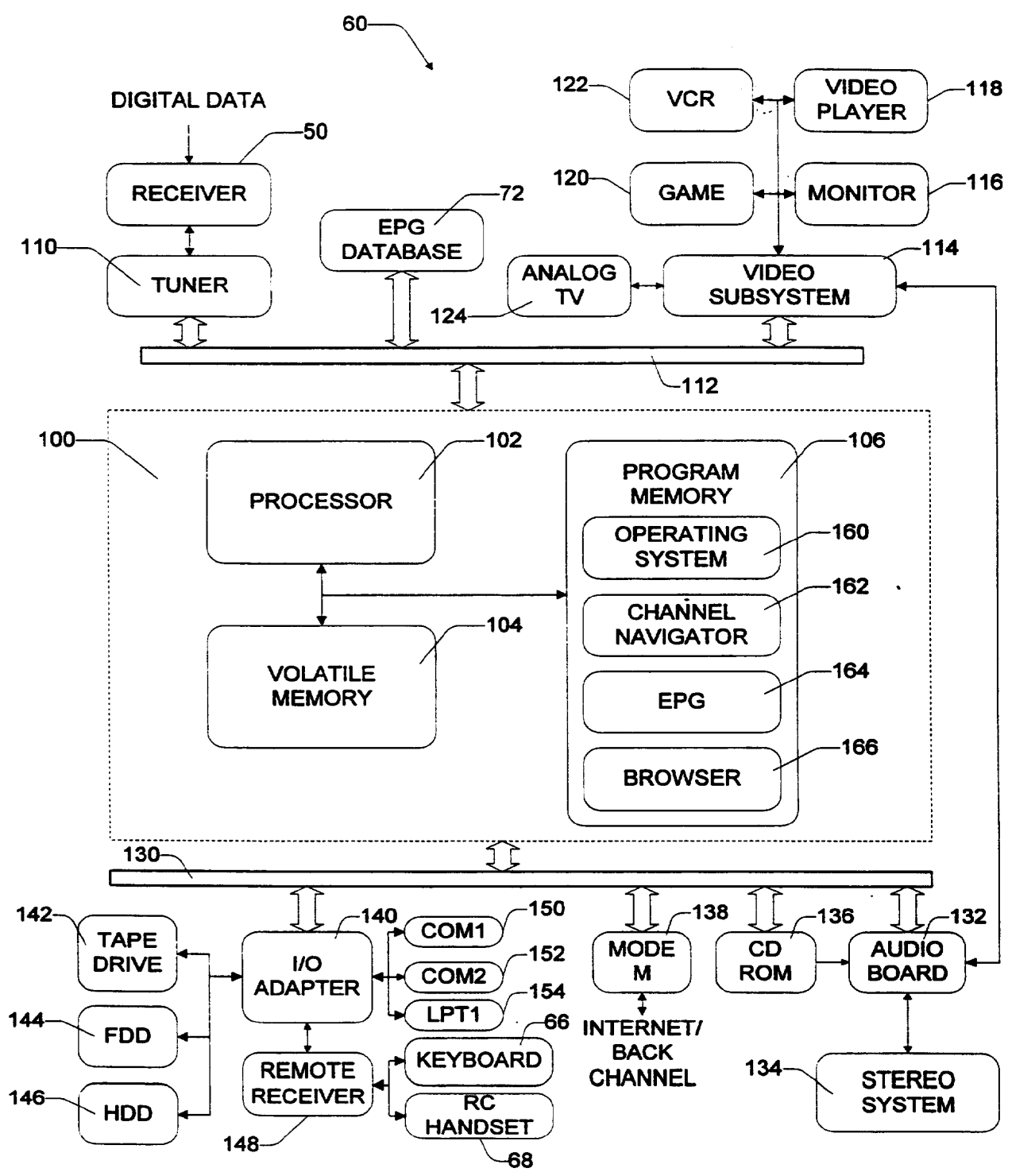

Fig. 5

6/12

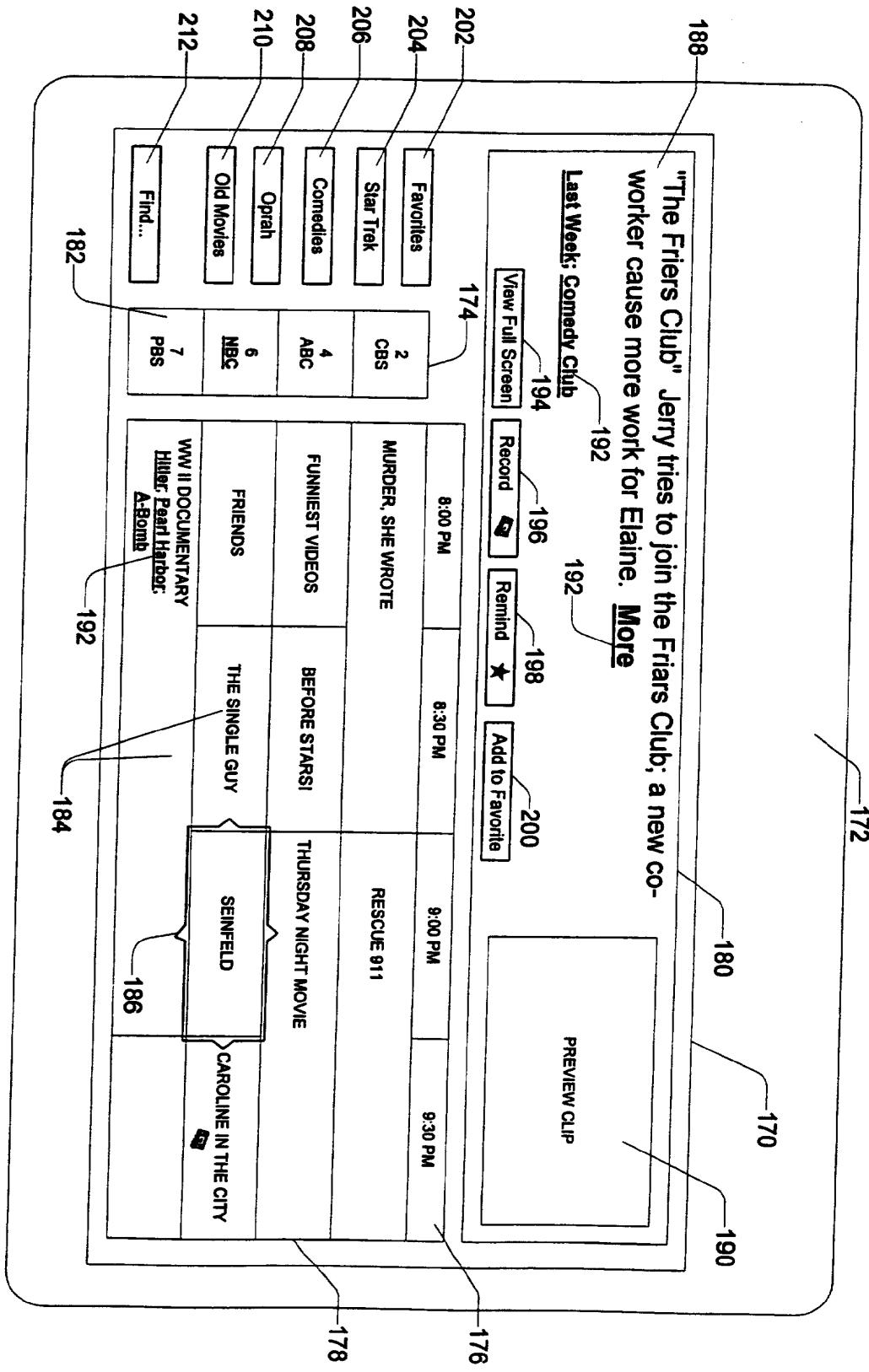

Fig. 6

7/12

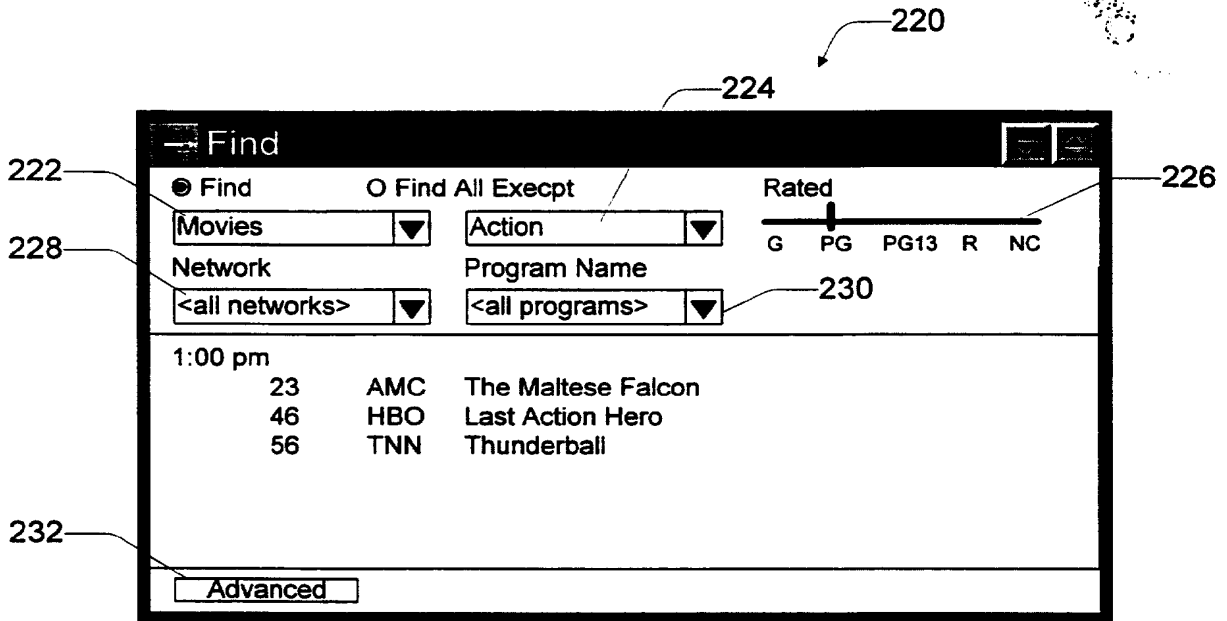

Fig. 7

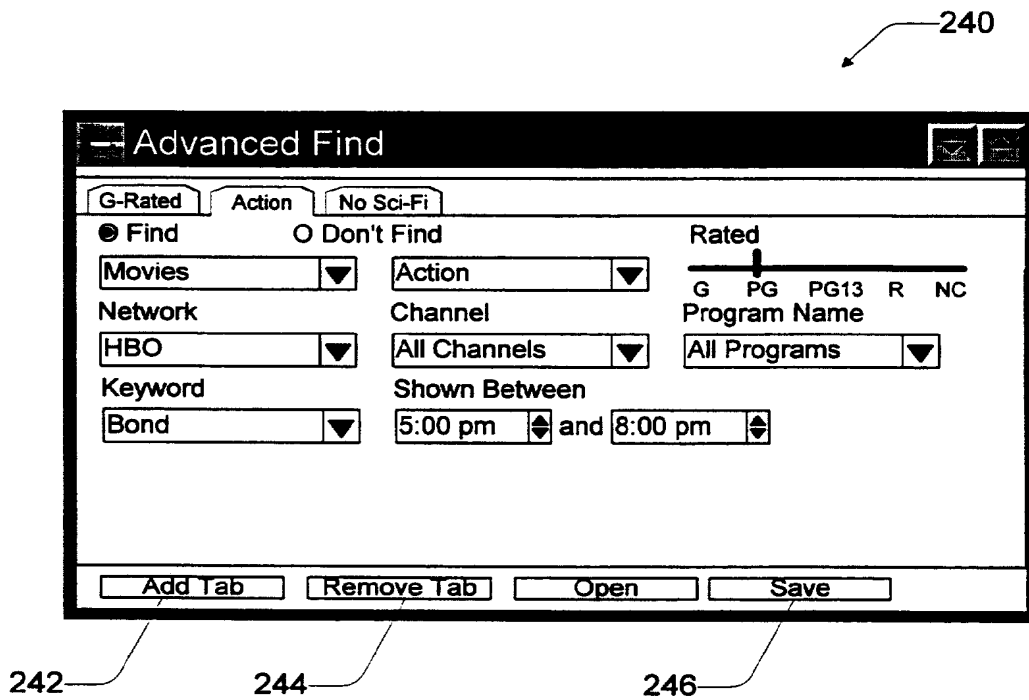

Fig. 8



8/12

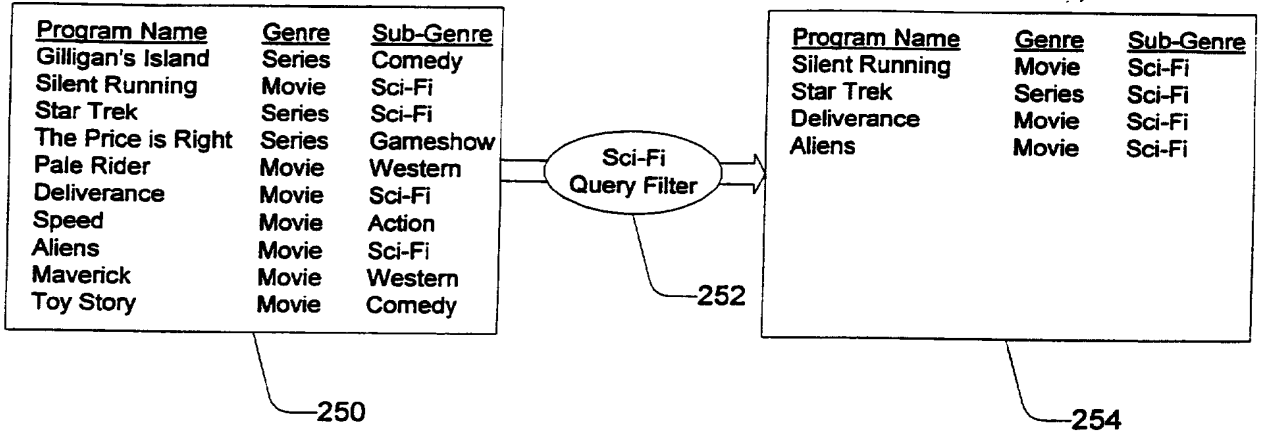

Fig. 9

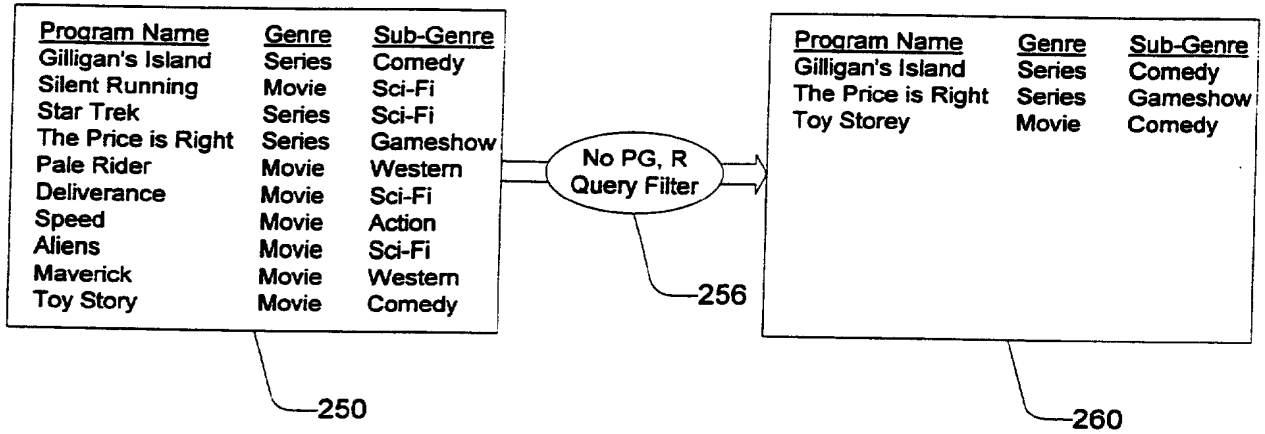

Fig. 10

9/12

260

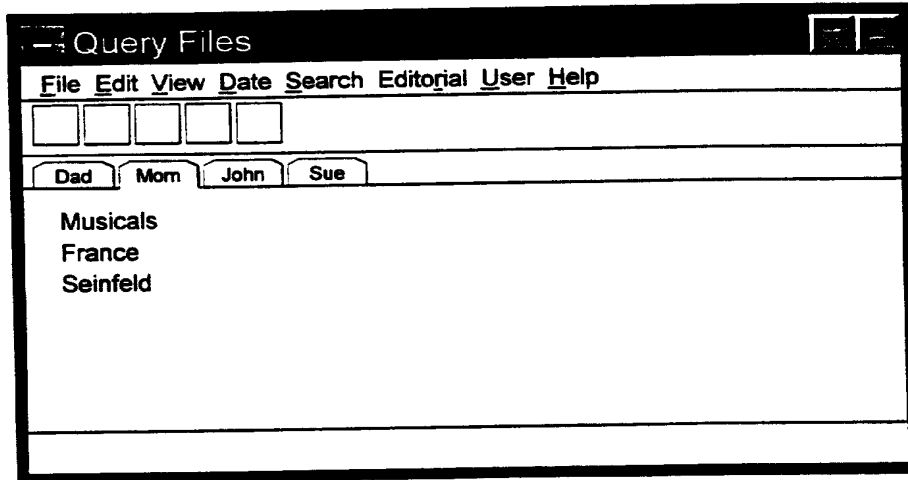

Fig. 11

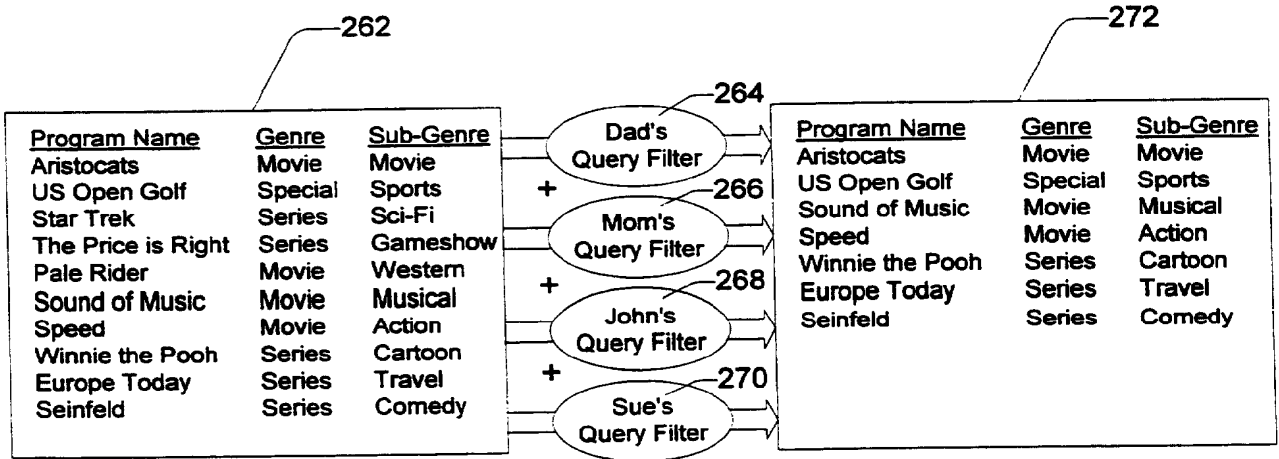

Fig. 12

10/12

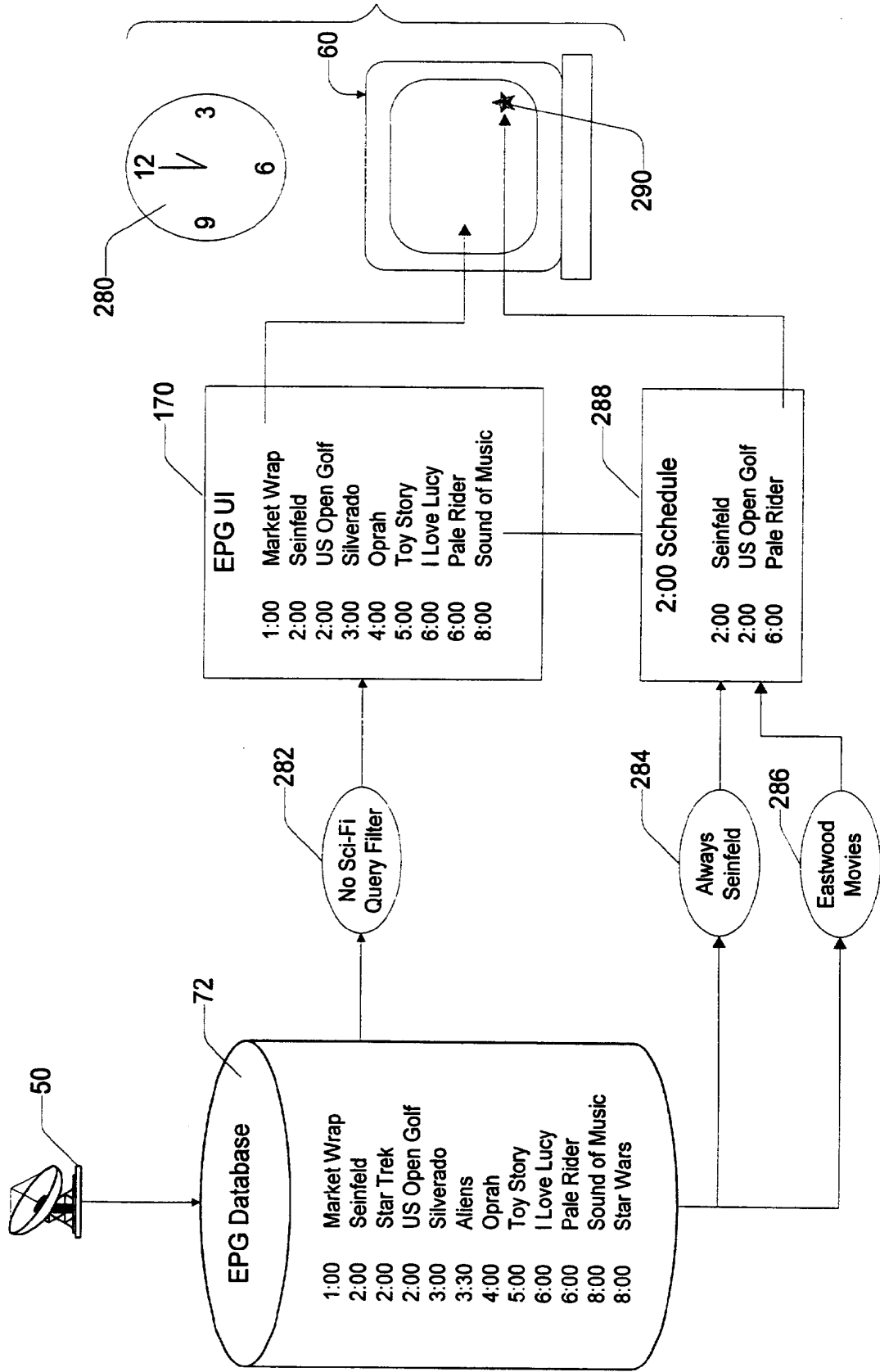

Fig. 13

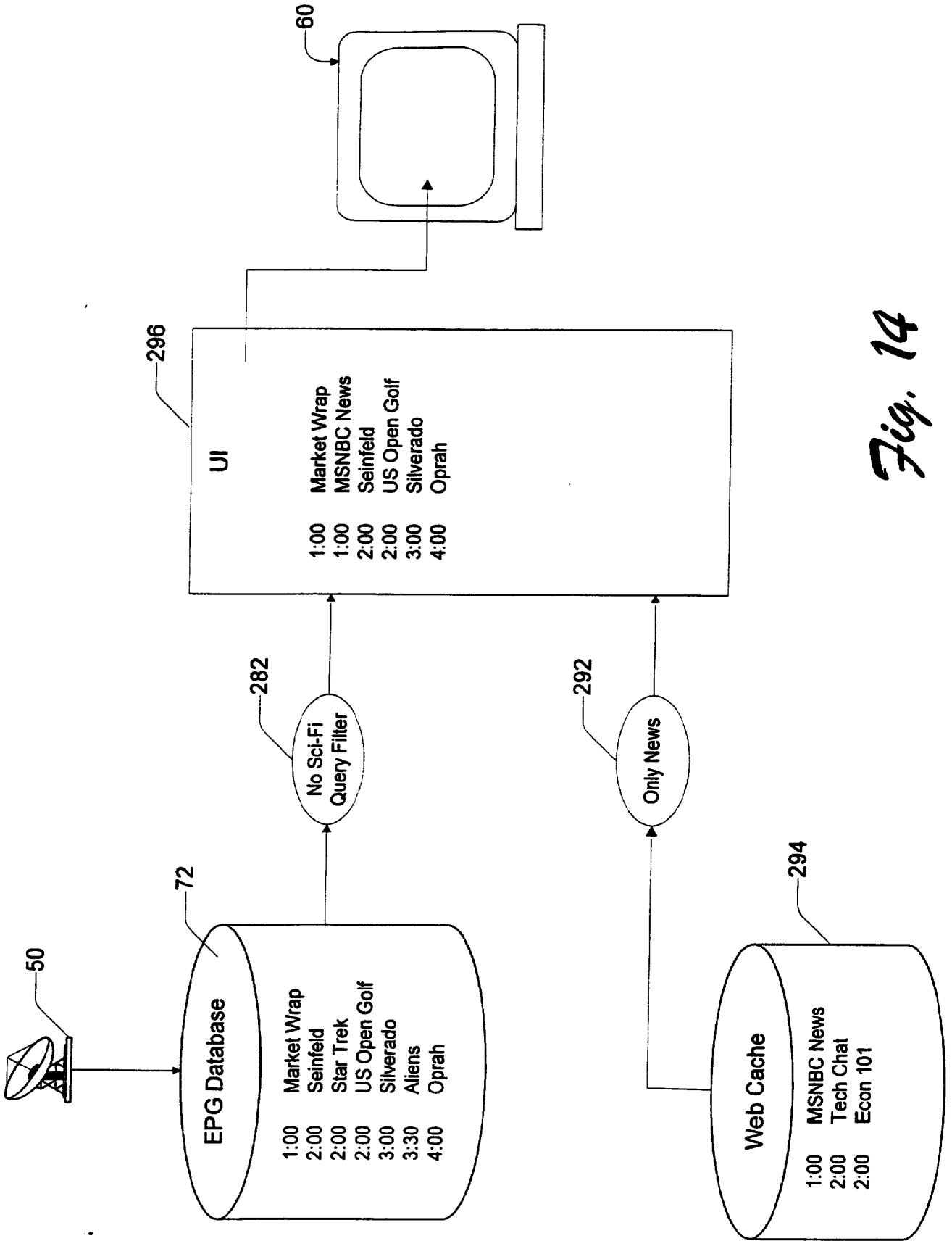

Fig. 14

12/12

300

| Quick Find                    |   |
|-------------------------------|---|
| Enter Network or Program Name |   |
| Magic                         |   |
| Network                       | Program Name                              |
| ESPN                          | Orlando Magic v. Chicago Bulls            |
| WGN                           | Chicago Bulls at Orlando Magic            |
| DSC                           | Magical World of Science                  |
| DISN                          | Tour of the Magic Kingdom at Disney World |

*Fig. 15*

QUERY-BASED ELECTRONIC PROGRAM GUIDE**TECHNICAL FIELD**

This invention relates to entertainment systems, such as interactive television or interactive computing network systems, and to electronic program guides which operate in conjunction with these systems. More particularly, this invention relates to methods for operating electronic program guides using auto-generated and viewer-generated queries to identify programs or other programming information.

**BACKGROUND OF THE INVENTION**

Television viewers are very familiar with printed programming schedules that appear in daily newspapers or weekly magazines, such as TV Guide®. The printed program guide lists the various television shows in relation to their scheduled viewing time on a day-to-day basis.

Cable TV systems often include a channel with a video broadcast of the printed program guide. The cable channel is dedicated to displaying listings of programs available on the different available channels. The listings are commonly arranged in a grid. Each column of the grid represents a particular time slot, such as 4:00 p.m. to 4:30 p.m. Each row represents a particular broadcast or cable channel, such as ABC, PBS, or ESPN. The various scheduled programs or shows are arranged within the rows and columns, indicating the channels and times at which they can be found. The grid is continuously scrolled vertically so that a viewer watches a continuously refreshing set of programs within three or four time slots.

Data for available programs is typically received by a cable system as a plurality of data records. Each available program has a single corresponding data

1 record indicating a variety of information about the program such as its channel, its  
2 starting and ending times, its title, names of starring actors, whether closed-  
3 captioning and stereo are available, and perhaps a brief description of the program.  
4 It is not difficult to format a grid such as described above from this type of data  
5 records. The grid is typically formatted once at the cable system's headend and  
6 broadcast repeatedly and continuously to the thousands of homes served by the  
7 cable system.

8 Newer, interactive cable distribution systems feature electronic program  
9 guides (EPGs) which function somewhat similar to the broadcast program listing  
10 channels described above. Rather than scrolling automatically, however, an EPG  
11 allows a viewer to use a remote control device or other input device to scroll as  
12 desired both horizontally and vertically through a program grid. This functionality  
13 utilizes the two-way communications capabilities of interactive cable systems.

14 The EPG is typically implemented in software which runs on a set-top box  
15 (STB) connected between a TV and a cable system home entry line. When  
16 scrolling to a new column or row, the set-top box inserts the appropriate  
17 programming information into each new row or column. This information is either  
18 cached at the STB, or requested from the cable system's headend.

19 Interactive systems permit viewers to control what programs are shown on  
20 their TV and when. Movies-on-demand is one example of this interactive control.  
21 A viewer can peruse a list of available movies from the EPG, and then order a  
22 selected movie. The STB sends a request for the movie to the headend server.  
23 The movie is retrieved and transmitted to the requesting STB. Movies-on-demand  
24 thus enables viewers to shop, purchase, and watch a movie at their convenience, as  
25

1 opposed to being restricted to certain start times as is typical with conventional  
2 premium or pay-per-view channels.

3 Many industry and commercial experts expect entertainment systems to  
4 evolve to the point of offering many other interactive services to the consumers.  
5 For instance, consumers will be able to use their TV or computer to shop for  
6 groceries or other goods, conduct banking and other financial transactions, play  
7 games, or attend educational courses and take exams.

8 Conventional distribution networks support many channels. It is common  
9 for a TV audience to have 50 to 100 channels. However, as technology improves  
10 and programming content continues to expand, the number of channels are  
11 expected to increase dramatically to many hundreds, or even thousands of  
12 channels.

13 One problem with the growth in the number of channels is that vastly  
14 enlarged selection, while appealing to a viewer, will make it more difficult for a  
15 viewer to locate programs of their preference. Traditional methods of locating  
16 programs—such as memorizing channel numbers, scanning program grids, or  
17 random surfing—will become less effective as the number of channels increase.  
18 For example, imagine the difficulty in trying to present hundreds or thousands of  
19 programs in a scrollable grid-like EPG user interface (UI), which might show only  
20 a few programs or channels at one time. This UI structure will most likely be  
21 unworkable for large program and channel offerings. Additionally, surfing  
22 through hundreds or thousands of channels will likely consume a large amount of  
23 time, causing the viewer to miss the programs he/she is attempting to find.

24 It is also likely that the traditional practice of relating programs and  
25 networks to specific channels will become less meaningful as the number of



1 channels increases. Suppose, for example, a viewer might be interested in  
2 watching football. Today, a viewer might remember that channel 6 (NBC) and  
3 channel 3 (FOX) carry the football games and simply tune to one of these  
4 channels. In the future, however, there might be football games being broadcast  
5 on channels 78, 495, and 1042. These channels might be small local stations that  
6 are broadcasting their local football team, or one of many channels used by a  
7 major network. Viewers are not likely to remember that channels 78, 495, and  
8 1042 are carrying football games at specific times.

9 Moreover, the correlation of channels to networks and programs vary from  
10 market to market. For instance, the sports network ESPN might be carried on  
11 channel 15 in one market and on channel 29 in another market. Memorizing  
12 program offerings in terms of channel numbers will prove frustrating as a viewer  
13 travels from one market to the next.

14 Accordingly, there is a need to develop operating methods which allow  
15 viewers to easily find programs or networks regardless of the channels on which  
16 they are carried. Additionally, these operating methods should enable viewers to  
17 locate programs regardless of whether they remember the channel number,  
18 program name, or network name.

19 Toward this end, a company named TVHost, Inc. has developed a software-  
20 based product "ETV" which assists a viewer in locating particular programs. The  
21 ETV system organizes the different program offerings according to different  
22 topical categories. Fig. 1 shows an example screen display of a graphical user  
23 interface (UI) window 20 supported by the ETV system. The ETV window 20 has  
24 a first pane 22 that lists alphabetically predefined types of programs, such as  
25 Business, Children, Educational, Game Shows, and so forth. The viewer can

1 control a focus frame or highlight bar 24 to choose a type of program from the first  
2 pane 22. A second pane 26 contains a list of programs that are available for the  
3 program type highlighted in the first pane 22. In this example, the type "business"  
4 is highlighted, and hence business-related programs are shown in the second pane  
5 26. The second pane 26 also provides other programming information including  
6 start time, network or station, and duration.

7 The ETV system thereby offers an alternative to a scrollable grid  
8 presentation which organizes programs according to type. This allows the viewer  
9 to select a program type, and then review the programs offered for this type. The  
10 ETV system also permits rudimentary "search" capabilities. Fig. 2 shows another  
11 graphical UI window 30 which appears when performing a search. A first pane 32  
12 contains a scrollable alphabetized list of stations, and allows a viewer to choose a  
13 station. A second pane 34 contains a scrollable alphabetized list of program types  
14 from which the viewer may select a program type. Other parameters, such as  
15 MPAA, rating, and start time, can also be selected by the viewer. Based upon  
16 these selections, the ETV system locates programs which are of a particular type,  
17 from the selected station, and satisfy the ratings and start times.

18 The ETV system is limited in many respects. The ETV system does not  
19 permit searches on arbitrary fields. Instead, the categories are predefined for the  
20 viewer. The viewer is not able to define his/her own complex searches using, for  
21 example, Boolean logic of "OR," "AND," and "NOT." Another limitation is that  
22 the ETV system does not provide any active controls which intelligently narrows  
23 selections based upon viewer selections. An "active" control is a control that does  
24 not require any other action on the part of the user. For instance, if a viewer  
25 selects a station in pane 32 of the search window 30 (Fig. 2), all program types will

1 be listed in the second pane 34. In fact, the same lists will always occur in both the  
2 first and second panes 32, 34 regardless of what selections the viewer has  
3 previously made. The viewer is not able to see any results until the viewer  
4 activates a "Begin" search key 36.

5 Accordingly, there remains a need to develop operating methods which  
6 decouple associations between the channel and network or program and also allow  
7 intelligent search procedures to better assist the viewer in locating preferred  
8 programs.

### 9 10 **SUMMARY OF THE INVENTION**

11 This invention concerns an electronic program guide (EPG) which enables  
12 creation of queries to facilitate simple and complex searches across predefined and  
13 arbitrary fields. The EPG organizes and presents programming information to a  
14 viewer. The EPG is implemented in software which executes on a processor  
15 resident in a viewer computing unit. As described herein, the viewer computing  
16 unit can be implemented as a set-top box (STB) connected to a television (TV), as  
17 a computer and monitor, or the like.

18 According to one aspect of this invention, the EPG is configured to  
19 automatically identify programs that a viewer is likely to prefer. The EPG collects  
20 viewing preferences of a viewer by, for example, monitoring and logging viewing  
21 habits of the viewer or through creation of a viewer profile in which a viewer  
22 answers a series of questions designed to discover the viewer's likes and dislikes.  
23 Based upon the these viewer preferences, the EPG automatically develops queries  
24 for identifying programs that the viewer is likely to watch and presents those  
25 programs to the viewer.

1           The EPG can further be configured to merge the queries of individual  
2 viewers into a composite query which searches for programs on behalf of all  
3 viewers. Each viewer defines his/her own query. For instance, one family  
4 member might define a query for college basketball games, another family  
5 member might define a query for Civil War programs, and another family member  
6 might define a query for cartoons. The EPG then creates a unified query which  
7 combines the three queries to jointly identify programs which satisfy any one of  
8 the three queries.

9           The EPG saves queries in a hierarchic structure to make it easy for a viewer  
10 to organize and retrieve queries. The viewer can define directories and sub-  
11 directories to organize the queries. For instance, a viewer might arrange queries  
12 for different kinds of movies within a Movie directory and queries for sports  
13 within a Sports directory. Another example organization is to arrange queries  
14 within separate user directories.

15           According to another aspect, the EPG is configured to run queries in  
16 background so that the queries are periodically executed unbeknownst to the  
17 viewer. When the EPG identifies a particular program satisfying the background  
18 query, the EPG automatically notifies the viewer of the program and/or  
19 automatically initiates procedures to record the program. For example, suppose a  
20 viewer wants to watch shows on the Great Wall of China. The viewer can define a  
21 query for identify any programs mentioning the Great Wall and have the query  
22 execute in background, perhaps for a long duration of time. As the EPG identifies  
23 programs on the Great Wall, the EPG notifies the viewer of when the program is  
24 scheduled to be shown, and to initiate recording procedures.

1 According to another aspect of this invention, the EPG assists a viewer in  
2 finding a program, channel number, or network by using a 10-key keypad as  
3 typically found on remote control handsets. The keypad has ten numerical keys,  
4 which also correspond to associated letters. When the viewer presses a key, the  
5 viewer might intend to be entering a number to find a channel, or one of the letters  
6 associated with the key for spelling the program or network name. Regardless of  
7 the viewer's intent, the data generated when the key is depressed is the same. The  
8 EPG is configured to interpret the data as representing all possible choices,  
9 including the number and letters associated with the key. For instance, when a  
10 viewer depresses the number "5" key, the EPG interprets that data to mean "5" or  
11 "J" or "K" or "L." The EPG then identifies programs, channels, and networks  
12 which begin with or contains the number or letters. As the viewer continues to  
13 enter each digit, the list of programs, channel, and networks dynamically narrows.  
14 After a few button presses, the viewer is presented with a short list of possible  
15 choices.

## 16 **BRIEF DESCRIPTION OF THE DRAWINGS**

17  
18 Fig. 1 is an exemplary screen illustration of a graphical user interface (UI)  
19 window presented by a prior art product which organizes programs into predefined  
20 categories.

21 Fig. 2 is an exemplary screen illustration of a graphical user interface (UI)  
22 window presented by the prior art product which assists a viewer in searching the  
23 predefined categories to locate certain kinds of programs.

24 Fig. 3 is a diagrammatic illustration of an entertainment system.  
25

1 Fig. 4 is a simplified example of data fields in a data structure maintained  
2 by an electronic program guide (EPG).

3 Fig. 5 is a block diagram of a viewer computing unit.

4 Fig. 6 is an exemplary screen illustration of an EPG UI, and particularly, a  
5 screen having a scrollable grid with program listings.

6 Fig. 7 is an exemplary screen illustration of an EPG UI, and particularly, a  
7 screen used to help create simple queries for searching the EPG.

8 Fig. 8 is an exemplary screen illustration of an EPG UI, and particularly, a  
9 screen used to help create more advanced queries for searching the EPG.

10 Fig. 9 is a diagrammatic illustration of how a query filters the program  
11 database of the EPG to identify programs satisfying the parameters of the query.

12 Fig. 10 is a diagrammatic illustration of how a restrictive query filters the  
13 program database of the EPG to identify and prevent programs satisfying the  
14 parameters of the query from being displayed.

15 Fig. 11 is an exemplary screen illustration of an EPG UI, and particularly, a  
16 screen used to manage queries for multiple viewers.

17 Fig. 12 is a diagrammatic illustration of how individual queries can be  
18 merged into a composite query used to search the program database of the EPG.

19 Fig. 13 is a diagrammatic illustration of how program information is filtered  
20 through multiple queries to provide a short set of programs that are ultimately  
21 displayed to the viewer.

22 Fig. 14 is a diagrammatic illustration of how program information in an  
23 EPG database and other content information in a Web cache are filtered using  
24 multiple queries to provide a short set of programs that are ultimately displayed to  
25 the viewer.

1 Fig. 15 is an exemplary screen illustration of an EPG UI, and particularly, a  
2 screen used to locate a particular channel, network name, or program name and to  
3 create queries which search for them simultaneously.

#### 4 5 **DETAILED DESCRIPTION OF THE PREFERRED EMBODIMENT**

6 Fig. 3 shows an entertainment system 40 according to one implementation  
7 of this invention. System 40 includes a centralized headend or content provider 42  
8 which is configured to provide continuous video content programs to multiple  
9 subscribers. Programs provided by content provider 42 might include traditional  
10 broadcast TV shows, on-demand movies, games, and other services such as those  
11 commonly provided in the past by on-line computer services.

12 The content provider 42 supplies video and other data over a distribution  
13 network 44 to the subscribers. In this implementation, the network 44 is a satellite  
14 network which transmits the data in a digital format from the content provider  
15 directly to individual subscribers. The satellite network 44 includes a transmitter  
16 46, an orbiting satellite 48, and a receiver 50. As one example, the satellite  
17 network 44 can be implemented using DSS (Direct Satellite System) technology,  
18 where individual subscribers own small 18" receiving dishes 50 which are resident  
19 at their homes. Video, audio, and other data are transmitted in digital format from  
20 the satellite transmitter 46 to the orbiting satellite 48, where the data are redirected  
21 to the satellite receiver 50.

22 The distribution network 44 can be implemented in other ways instead of  
23 DSS technology. One implementation is a multi-tier network which includes a  
24 high-speed, high-bandwidth fiber optic cable network between the content  
25 provider 40 and regional distribution nodes (not shown), and conventional home

1 entry lines, such as twisted-pair lines or coaxial cable, between the distribution  
2 nodes and viewer computing units 60. Another network implementation might  
3 include traditional RF broadcast technologies. The network can also be  
4 constructed using a combination of wireless and wire-based technologies.

5 Another approach beside to broadcasting the content to the subscribers is by  
6 multicasting the content over the Internet. With this approach, the content  
7 providers transmit the data content to a designated multicast address on the  
8 Internet. Subscribers listen to the multicast address to receive the primary content.

9 Each subscriber residence has at least one viewer computing unit 60. In the  
10 illustrated implementation, the viewer computing unit 60 is embodied as a  
11 broadcast enabled personal computer, or simply "broadcast PC." The broadcast  
12 PC 60 has a large computer monitor 62, a processing unit 64, and input devices in  
13 the form of remote keyboard 66 and/or remote control handset 68. The remote  
14 keyboard 66 and handset 68 are remotely coupled to the processing unit 64 via a  
15 wireless data link 70, such as infrared (IR) or radio (RF), although the remotes can  
16 be directly connected. The broadcast PC 60 also includes an EPG database 72 and  
17 a content separator 74, which are shown separately for illustration purposes, but  
18 can be incorporated into the processing unit 64.

19 It is noted that the viewer computing unit 60 can be implemented in other  
20 forms. For instance, the viewer computing unit 60 can be embodied as a set-top  
21 box coupled to a conventional television. Another implementation includes a TV  
22 or other visual display device, which has processing components incorporated  
23 therein.

24 Content provider 42 is configured to originate the broadcast programs or to  
25 rebroadcast programs received from another source, such as a satellite feed or



1 another cable system. In addition, the content provider 42 is configured to  
2 maintain a database of programs 80, such as feature-length movies, past TV  
3 shows, games, and other entertainment videos, which can be played individually to  
4 requesting subscribers in an on-demand mode. These programs can be requested  
5 via a back channel, such as a telephone link or Internet link (described below). In  
6 the case of a cable based network, the cable might function as both distribution  
7 channel and back channel to support interactivity. As technology continues to  
8 improve, the receiver 50 might be replaced with a transceiver which is capable of  
9 both receiving digital data from the satellite system, and transmitting data back  
10 across the satellite system.

11 The content provider 42 includes a continuous media server 82 which  
12 distributes the digital video data streams kept in the programs database 80. The  
13 continuous media server and video program database are implemented, for  
14 example, as a disk array data storage system consisting of many large capacity  
15 storage disks. The video data streams of the movies are stored digitally on the  
16 storage disks in predetermined or mapped locations. The locations of the video  
17 data streams are kept in a memory map and each video data stream is accessed  
18 through pointers to the particular memory location. The continuous media server  
19 can service simultaneous requests for a program (even the same program) from  
20 many viewers.

21 The content provider 42 also has an program information server 84 to serve  
22 programming information to the viewer computing unit 60. The program  
23 information server 84 is implemented as a structured query language (SQL)  
24 database 86 with records containing information relating to available shows or  
25 programs.

1 Fig. 4 shows an example data structure 88 for organizing programming  
2 information within the EPG database 86. The data structure includes various data  
3 fields 90 for holding programming information. The data fields contain program  
4 titles, actor names, whether the program has closed captioning or stereo audio, the  
5 scheduled time of the program, the network name, description text, and the like.  
6 The data structure 88 holds pointer to locations within the storage subsystem of the  
7 continuous media server 82 which identify storage locations of the programs  
8 corresponding to the program records.

9 The data structure 88 might also contain target specifications (memory  
10 pointer, hyperlink, etc.) to one or more target resources which maintain  
11 supplemental content for the programs. The supplemental content can be stored at,  
12 and served from, the content provider 42 or from an independent service provider.  
13 The supplemental content can be text, hypermedia, graphics, video, picture, sound,  
14 executable code, or other multimedia types which enhance the broadcast program.  
15 Examples of possible supplemental content include interactive questions or games  
16 related to the program, additional trivia on the movies or TV shows,  
17 advertisements, available merchandise or other memorabilia, Web pages to  
18 programs of similar type or starring the same actors/actresses, and so on.

19 With reference again to Fig. 3, the content provider 42 broadcasts multiple  
20 programs for different networks and channels as one continuous digital data feed,  
21 as is conventional in DSS. The EPG programming information is transmitted  
22 along with the video and audio data. The data is compressed and placed in digital  
23 transport packets for transmission over the satellite system. If desired, the data  
24 pertaining to particular channels or programs can be scrambled. The receiver 50  
25 de-scrambles and decompresses the data stream, and then reconstructs the video,

1 audio, and programming data from the digital transport packets. The content  
2 separator 74 separates the video and audio data from the programming  
3 information. The video/audio data is directed to a tuner in the viewer computing  
4 unit 60 which selects a particular channel and displays the video on the monitor 62  
5 and plays the corresponding audio. The viewer controls program selection using  
6 the keyboard 66 or remote control handset 68. The programming information is  
7 input to the EPG database 72. By caching the programming information in the  
8 local EPG database 72, interactive functionality used to locate and select certain  
9 programs from the EPG is handled locally.

10 The entertainment system 60 also includes an independent service provider  
11 (ISP) 92 which distributes digital content to the viewer computing unit 60 over a  
12 second network 94. An example of the second network 94 is a public network,  
13 such as the Internet. The ISP 92 has an ISP host 96 and a content database 98 to  
14 serve various multimedia content to the user. For instance, the ISP host 96 might  
15 store one or more target resources (such as a Web page) that can be rendered by  
16 the viewer computing unit 62.

17 According to the Fig. 3 arrangement, the viewer computing unit 60 receives  
18 traditional broadcast, on-demand programs, and programming information from  
19 the content provider 42. The viewer computing unit 60 also receives supplemental  
20 interactive content from the content provider 42 or from the independent service  
21 provider 92. The back channel for facilitating interactive control is provided  
22 through network 94. The off-site supplemental information provided by the ISP  
23 92 is correlated with the programs within the program records data structure 88 in  
24 program information server 84. As shown in Fig. 4, programs with supplemental  
25

1 content provided by other servers has a target specification listed in one of the data  
2 fields.

3 Fig. 5 shows an example implementation of the viewer computing unit 60  
4 in more detail. It includes a mother board 100 having a processor 102 (e.g., x86 or  
5 Pentium® microprocessor from Intel Corporation), a volatile memory 104, and a  
6 program memory 106. The viewer computing unit 60 includes a digital broadcast  
7 receiver 50, such as a satellite dish receiver (Fig. 3). The digital receiver 50  
8 receives digital data broadcast over the satellite distribution network 44. The  
9 receiver 50 is coupled to a tuner 110 which tunes to frequencies of the satellite  
10 transponders in the satellite distribution network. The tuner 110 has one or two  
11 primary components: a specialized digital broadcast tuner and/or a generalized  
12 digital broadcast tuner. The specialized digital broadcast tuner is configured to  
13 receive digital broadcast data in a particularized format, such as MPEG-encoded  
14 digital video and audio data. The generalized digital broadcast tuner is configured  
15 to receive digital data in many different forms, including software programs and  
16 programming information in the form of data files.

17 The tuner 110 is connected to the mother board 100 via a multi-bit bus 112,  
18 such as a 32-bit PCI (Peripheral Component Interconnect) bus. The EPG database  
19 72 is shown connected to the PCI bus 112, but can alternatively be implemented as  
20 part of a hard disk drive 146. The programming data received at the receiver 50 is  
21 transferred over the PCI bus 112 to the EPG database 72. A decryption device (not  
22 shown) for facilitating secure access to the broadcast enabled PC may also be  
23 attached to the bus 112.

24 The viewer computing unit 60 has a video subsystem 114 connected to the  
25 PCI bus 112. The video and audio data is transferred from tuner 110 over PCI bus

1 112 to the video subsystem 114. The video subsystem 114 includes circuitry for  
2 decoding MPEG-encoded or other video data formats, although such circuitry can  
3 alternatively be incorporated into the tuner 110 or motherboard 100. The video  
4 subsystem 114 also includes video display drivers for driving a computer monitor  
5 116.

6 The video subsystem 114 supports many peripheral devices, in addition to  
7 the monitor 116. For instance, the video subsystem 114 might be connected to a  
8 laser video player 118 for playing DVD (digital video disks), a game machine 120  
9 for playing video games, and a VCR (video cassette recorder) 122 for recording  
10 programs. The video subsystem 114 is adapted for connection to an analog  
11 broadcast television system 124 to receive conventional TV signals from cable  
12 television or RF broadcast television systems. This enables backwards  
13 compatibility to analog TV systems.

14 The monitor 116 is preferably a VGA or SVGA monitor as is customary for  
15 personal computers, as opposed to a standard television. In the illustrated  
16 implementation, the viewer computing unit 60 does not convert the television-  
17 related data into an NTSC (National Television System Committee) format. In  
18 this manner, the viewer computing unit 60 is able to produce television data having  
19 superior quality when displayed on the VGA monitor.

20 The viewer computing unit 60 also includes a second bus 130, such as an  
21 ISA (Industry Standard Architecture) bus, coupled to the mother board 100. An  
22 audio board 132 is coupled to the ISA bus 130 and serves as an interface with a  
23 number of audio output devices, such as conventional speakers. An amplifier may  
24 be coupled between the audio board and speakers if desired. The audio board is  
25 also coupled to the video subsystem 114 to receive decoded audio signals. The

1 audio board 132 can be coupled to a stereo system 134, so that audio data can be  
2 output to the stereo system for enhanced sound and recorded.

3 A CD ROM drive 136 is coupled to the ISA bus 130. The audio output  
4 produced by the CD ROM drive 136 is passed to the audio board 132.

5 The viewer computing unit 60 includes a modem 138, such as a 14.4 or  
6 28.8 kbps fax/data modem, coupled to the ISA bus 130. The modem 138 is  
7 connected to a conventional telephone line and provides access to public networks,  
8 including the Internet. The modem 138 can be used to access and download data  
9 and supplemental content directly from an independent service provider.  
10 Additionally, the modem 138 can be used for two-way communications with the  
11 content provider serving the programs over the DSS network. Viewer requests for  
12 programs can be transmitted over the back channel via the modem 138.

13 An input/output (I/O) adapter 140 is coupled to the ISA bus 130 to interface  
14 with numerous I/O devices , including a digital tape driver 142, a floppy disk drive  
15 144, and a hard disk driver 146. A remote receiver 148 is also coupled to the I/O  
16 adapter 140 for receiving signals from the remote cordless keyboard 66 and remote  
17 control handset 68 in an IR or RF format. Alternatively, the keyboard and handset  
18 can be directly wired to the computer. The I/O adapter 140 further provides  
19 conventional serial ports, including a COM1 port 150, a COM2 port 152, and an  
20 LPT1 port 154. An IR transmitter (not shown) can be coupled to the COM1 port  
21 150 to generate infrared signals to control electronic devices, such as stereo  
22 equipment, VCR, and the like. The computer 60 can also be hooked directly to  
23 these components.

24 The viewer computing unit 60 runs an operating system 160 which supports  
25 multiple applications. The operating system 160 is loaded in memory 106 and

1 executes on the processor 102. The operating system 160 is preferably a  
2 multitasking operating system which allows simultaneous execution of multiple  
3 applications. The operating system 160 employs a graphical user interface  
4 windowing environment which presents the applications or documents in specially  
5 delineated areas of the display screen called "windows." One preferred operating  
6 system is a Windows<sup>(rtm)</sup>® brand operating system sold by Microsoft Corporation,  
7 such as Windows<sup>(rtm)</sup>® 95 or Windows<sup>(rtm)</sup>® NT or other derivative versions of  
8 Windows<sup>(rtm)</sup>®. The remote keyboard 66 and handset 68 may include customized  
9 keys suitable for use with a Windows<sup>(rtm)</sup>® brand operating system. It is noted,  
10 however, that other operating systems which provide windowing environments  
11 may be employed, such as the Macintosh operating system from Apple Computer,  
12 Inc. and the OS/2 operating system from IBM.

13 A channel navigator application 162 is stored in program memory 106 and  
14 executes on the processor 102 to control the tuner 110 to select a desired channel  
15 for receiving the video content programs. An EPG application 164 is stored in  
16 program memory 106 and executes on the processor 102 to organize programming  
17 information downloaded from the Program information server at the content  
18 provider and cached in the EPG database 72. The EPG 104 supports a displayable  
19 user interface (UI) which visually presents the programming information from the  
20 EPG database 72 in a usable format for the viewer, as will be described below with  
21 reference to Fig. 6. The EPG is also configured to enable the viewer to define  
22 queries which intelligently identify and gather programs the viewer would like to  
23 see.

24 The viewer computing unit 60 has a browser 166 which is kept in memory  
25 106 and dynamically loaded on processor 102 when needed to render content, such

1 as a hypertext document, from an ISP or other content provider. The browser166  
2 can be implemented as a hyperlink browser, or more particularly, as an Internet  
3 Web browser.

4 It is noted that the operating system and applications can be stored on the  
5 hard disk driver 146, or other storage medium (floppy disk, CD ROM, etc.), and  
6 loaded into the program memory for execution by the processor.

7 It is further noted that the broadcast enabled personal computer 60 is a fully  
8 functional computer which can perform the typical desktop applications familiar to  
9 computers. A variety of different applications can be loaded and executed on the  
10 viewer computing unit. As an example, the viewer can run word processing  
11 applications, spreadsheet applications, database applications, scheduling  
12 applications, financial applications, educational applications, and so forth. The  
13 viewer operates the applications using the keyboard 66.

14 Fig. 6 shows an example EPG UI 170 which is presented on a display 172.  
15 The EPG UI 170 includes a channel panel 174, a time panel 166, a program grid  
16 178, and a program summary panel 180. Channel panel 174 provides a vertical  
17 scrolling list which displays multiple channel tiles 182 at any one time. Each  
18 channel tile 182 includes a channel number and a channel name (typically the  
19 network name, such as CBS, ABC, MTV, etc.), and might also include a channel  
20 logo. The channel panel 174 defines rows of program titles in program grid 178.  
21 Time panel 176 is a horizontal, continuous scrolling time line with markings  
22 denoting half-hour time segments. Time panel 176 defines columns in program  
23 grid 178.

24 Program grid 178 consists of multiple program tiles 184 organized in  
25 channel-based y-axis and time-based x-axis. The grid is located to the right of



1 channel panel 174 and below time panel 176. Each program tile 184 has the  
2 program title and any secondary program descriptive information, such as closed  
3 caption, stereo, etc. The illustrated screen shows an example programming line-up  
4 for 8:00 p.m. to 10:00 p.m. PST, Thursday, March 7, 1996. The program titles,  
5 such as "Murder, She Wrote" and "Friends," are arranged horizontally with respect  
6 to their networks CBS and NBC and vertically with respect to their start times of  
7 8:00 p.m. PST. It is noted that many other grid or non-grid layouts may be  
8 employed to present the program selections to the viewer. Additionally, although  
9 the layout is shown organized according to channel number, the same information  
10 can be presented in a channel absence presentation where no reference is made to  
11 channel numbers.

12 The viewer controls the program selection with a single focus frame 186  
13 which is graphically overlaid on the program grid 178. Focus frame 186 can be  
14 moved up or down, or left and right within a channel line-up, to choose a desired  
15 program. The remote control handset or keyboard (or other manipulating  
16 mechanism) can be used to position the focus frame 186 within the EPG UI 170.

17 Program summary panel 180 includes a text description window 188 and a  
18 preview window 190. The text description window 188 displays program  
19 information related to the program that is highlighted by the focus frame 186 in  
20 program grid 178. Here, the NBC program "Seinfeld" is highlighted and the text  
21 description window 188 lists the program title "Seinfeld," and a program  
22 description of the current episode. The text description window 188 might also  
23 include other program related information like closed-captioning, stereo, etc. The  
24 preview window 190 is used to display clips of the selected highlighted show, such  
25 as a preview of the "Seinfeld" show.

1           The data to fill the various tiles and windows is drawn from the EPG  
2 database 72 or from URL resources on the Internet 94. The data is maintained in  
3 data structure 88 (Fig. 2) which is transmitted as program records from the content  
4 provider over the satellite network to the viewer computing unit and cached in the  
5 EPG database 72. The EPG application 164 inserts the appropriate data records  
6 into the EPG UI 170 for display as the viewer maneuvers the focus frame 186  
7 around the grid.

8           The EPG UI 170 also includes hyperlinks 192 which are supplied with the  
9 program records received from the content provider, embedded in the program  
10 stream, or provided in a data stream from arbitrary source which has been  
11 associated with the program. The hyperlinks can be inserted into the channel tiles  
12 182, program tiles 184, or the description window 188. In the Fig. 6 illustration,  
13 the hyperlink "More" is provided in the description window 188 to reference target  
14 resources that contain additional information about this episode of the "Seinfeld"  
15 show. Other hyperlinks in the description window 188 include "Last Week"  
16 which references a target resource containing information on the previous week  
17 episode, and "Comedy Club" which links to a target resource having video  
18 coverage of comedian Jerry Seinfeld performing at night clubs. The target  
19 resources referenced by the hyperlinks might be located at the content provider or  
20 at an independent service provider. The target resource might further be located  
21 locally, having been pre-cached by the system. For instance, the system might pre-  
22 cache supplemental information about certain shows before they air based on  
23 predictive viewing tendencies, or as part of a promotional data broadcast  
24 advertising the show. This permits local interactive functionality between the  
25

1 viewer and the viewer computing unit, in addition to full network interactive  
2 functionality between the viewer and the program provider.

3 The EPG UI 170 has special operator buttons 194-200 which arrange for  
4 certain tasks. A "view full screen" button 194 allows the viewer to view the  
5 program in full screen. A "record" button 196 allows a user to initiate procedures  
6 to record a currently playing program, or schedule to record an upcoming program.  
7 For scheduling, the viewer simply drags the record icon and drops it on a program  
8 tile 184 of an upcoming program, as exemplified by the record icon dropped on the  
9 "Caroline in the City" program tile.

10 A "remind" button 198 is used to set reminders which notify viewer's of  
11 scheduled shows. A viewer might, for example, want to be reminded of a program  
12 being played later in the day and hence, drag a reminder icon to the suitable  
13 program tile 184. When the start time of the requested program approaches, the  
14 EPG will notify the viewer through a pop-up icon or the like that the program is  
15 about to begin. An "add to favorite" button 200 is provided to enable a viewer to  
16 add a program to a predefined list of favorites.

17 The drag and drop aspects described above are preferably implemented  
18 using object linking and embedding (OLE), which is commercially available from  
19 Microsoft Corporation under a technology known as "ActiveX." OLE is an  
20 extensible service architecture built on the Component Object Model (COM)  
21 which is both language independent and location independent. OLE supports an  
22 OLE Drag and Drop which is widely used in Windows®-compatible operating  
23 systems, such as Windows® 95. OLE and COM have been well documented and  
24 will not be explained in detail. For more information regarding OLE and COM,  
25 refer to OLE 2 Programmer's Reference and Inside OLE 2, Second Edition, both

1 published by Microsoft Press of Redmond, Washington, and both of which are  
2 hereby incorporated by reference.

3 The EPG UI 170 also presents predefined query buttons 202-210.  
4 Activation of these query buttons trigger a query of the EPG database 72 to  
5 identify programs satisfying the predefined query parameters. The EPG 106  
6 enables a viewer to create their own queries and to produce a soft button on the  
7 EPG UI 170 for quick retrieval of highly used queries. As an example, the EPG  
8 UI shows queries for favorite programs, Star Trek programs, comedies, the Oprah  
9 Show, and old movies. The "favorites" query button 202 recalls a list of programs  
10 that the viewer has previously identified as favorites using the "add to favorite"  
11 button 200, or which have been automatically defined as favorites by the EPG.  
12 The "Star Trek" query button 204 and "Oprah" query button 208 initiate queries of  
13 the EPG database 72 for all Star Trek and Oprah shows that might be playing  
14 within a particular time frame. As the number of channels increases and  
15 programming grows dramatically, several different channels might carry Star Trek  
16 or Oprah, concurrently or at different times. The "comedies" query button 206  
17 initiates a query of the EPG database 72 for all comedy programs. The "old  
18 movies" query button 210 locates all old movies that are showing.

19 Some of the predefined query buttons are preset categories, such as the  
20 "comedies" and "old movies" buttons, while other query buttons are defined by the  
21 viewer, such as "Star Trek" and "Oprah" buttons. The preset category buttons can  
22 be added and removed from the EPG UI through a separate window which allows  
23 a viewer to add or subtract categories from a list of available categories.

24 According to one aspect of this invention, the EPG 164 is configured to  
25 automatically develop queries to identify programs that a viewer is likely to want

1 to watch based on viewing preferences of the viewer. The EPG application  
2 collects viewer preferences in a number of ways. One technique is to log the  
3 amount of time that each channel is selected for viewing, with the underlying  
4 assumption that the viewer is watching that channel. Each channel is then  
5 assigned its own percentage of the entire viewing period as an indication of the  
6 viewer's preferences. The EPG generates a query to identify channels based upon  
7 this percentage, so that channels which the viewer tends to watch most often  
8 appear at the top of the list and channels which the viewer tends to watch least  
9 often appear at the bottom of the list. The EPG presents this list as a scrollable list  
10 in the EPG UI , with the highly watched channels appearing at the top and the least  
11 watched not appearing at all, but being available if the viewer wanted to scroll to  
12 them. It is noted that the same technique can be applied to individual programs or  
13 networks, where each program or network (rather than channel) is logged and the  
14 list is ordered with the frequently watched programs being listed on top and the  
15 least watched programs being listed on the bottom.

16 Another technique is to create a viewer profile for each viewer. The viewer  
17 is asked a series of questions directed at discovering the viewer's likes and  
18 dislikes. This question-and-answer session is accomplished using a separate  
19 graphical UI which asks questions and enables viewers to choose among  
20 responses, such as "strongly like," "like," "dislike," and "strongly dislike." Rather  
21 than discrete answers, the question-and-answer screen might include sliders which  
22 enable viewers to choose somewhere in a scale between opposing preferences of  
23 "strongly dislike" and "strongly like." The EPG compiles the viewer profile and  
24 correlates the profile with clustering data to generate a query for possible  
25 programs. The clustering data represents an accumulation of other viewers

1 preferences. By matching the viewer profile with similar profiles, the EPG can  
2 better determine what the viewer will most likely want to watch.

3       Once the EPG 164 has automatically compiled a list of likely favorites, the  
4 EPG presents the list in a UI screen. This screen can be called, for example, by  
5 activating the “favorites” button 202 in EPG UI 170. The list is presented as its  
6 own reduced, closed loop of available programs which has actively weeded out  
7 less popular channels. The viewer can then surf the closed list by sequentially  
8 cycling through the programs.

9       The EPG UI 170 also presents a “Find” button 212 which a viewer uses to  
10 create his/her own query. Activation of the “Find” button 212 opens another UI  
11 window which assists a viewer in creating a query. Fig. 7 shows an example find  
12 window 220. The find window 220 presents various search parameters for the  
13 viewer to search. In this example, the viewer can select a program genre from a  
14 genre box 222, a program sub-genre from a sub-genre box 224, a rating from the  
15 rating scale 226, a network name from the network box 228, and a program name  
16 from the program box 230. Based on these parameters, the EPG constructs a query  
17 and searches the EPG database 72 to locate programs satisfying the query. The  
18 find window supports creation of two mutually exclusive types of queries: a  
19 “find” query which locates all programs satisfying the search parameters and a  
20 “find all except” query to locate all programs which do not satisfy the parameters.  
21 In this example, the EPG has constructed a “find” query which located three  
22 programs that satisfy the parameters of an action movie rated PG.

23       To produce more advanced queries, the viewer can select an advanced  
24 query button 232. Fig. 8 shows an example advanced find window 240. It enables  
25 a viewer to create particularized queries and organize them in a tabbed folder

1 arrangement. In this example, the viewer has defined three advanced queries  
2 pertaining to "G-rated" programs, "Action" programs, and "No Sci-Fi" programs.  
3 The advanced find window 240 includes parameters such as genre, sub-genre,  
4 rating, network name, channel, program name, and time period. As new  
5 parameters are added to the EPG database, new controls in the advanced find  
6 window 240 are likewise added. It also allow a viewer to define a keyword. In  
7 this example, the viewer wants to find all James Bond action movies on HBO  
8 between 5:00 PM and 8:00 PM. Hence, the viewer enters the keyword "Bond" and  
9 executes the query. If the viewer wanted to find a particular bond movie starring  
10 Sean Connery, the viewer might enter a Boolean-like search "Bond AND  
11 Connery" in the keyword control of the advanced find window.

12 The advanced find window 240 can also be used to create restrictive queries  
13 which function to restrict or limit selection of programs for viewers without  
14 appropriate permissions levels. For instance, parents can set permission levels for  
15 their children so that when the children are logged onto the viewer computing unit,  
16 the children are prevented from watching certain programming content or from  
17 ordering certain services. A parent might, for example, wish to restrict a child  
18 from watching an R or NC rated movies. To create a restrictive query, the parent  
19 clicks the "don't find" option to convert the query from an inclusive query to an  
20 exclusive query.

21 An "add tab" button 242 and "remove tab" button 244 allow the viewer to  
22 manage the queries. The viewer can also save queries by clicking on the "save"  
23 button 246. Preferably, the queries are saved in a hierarchic query structure of the  
24 EPG database. This enables viewers to define directories and sub-directories of  
25 queries. Organizing queries in a hierarchic structure is advantageous because the

1 structure conforms to the computer side of the viewer computing unit and avails  
2 itself to memory management applications and tools running on the computer. As  
3 the number of saved queries grow, the query directories can be searched like other  
4 data files directories, as is common in personal computers, to locate a particular  
5 query. The query structure can also be presented in a UI to the viewer as an  
6 organization chart showing the hierarchy of directories, sub-directories, and  
7 queries. Individual queries can be saved as icons. To recall the query, the user  
8 activates the icon.

9 The EPG can also be configured to support a query editor to allow the  
10 viewer to create essentially any type of query based on key word descriptions, and  
11 to edit such queries. One suitable type of editor which can be employed with the  
12 EPG is a query editor used in a program entitled Cinemania95 by Microsoft  
13 Corporation, which enables a computer user to create queries for locating cinema  
14 trivia stored on the CD ROM.

15 To assist the viewer in defining a query (either by using the "Find" UI or  
16 the query editor), the EPG can provide wizards which guide the viewer with step-  
17 by-step instructions through the query creation. One example wizard for  
18 generating a simple query is to ask the viewer if the program selected is chosen for  
19 its name, or for its channel. A viewer might request to always be shown any  
20 program with one name, or to never display a program with another name.

21 Once a query is defined, the viewer can execute the query to initiate a  
22 search of the programming information in the EPG database 72. The queries  
23 function as a filter which sifts through the programming information and returns  
24 only those items which satisfy the parameters, or in the case of a restrictive query,  
25 precludes those items that satisfy the parameters.



1            Fig. 9 is a diagrammatic illustration of how a query operates to filter out  
2 programs which do not satisfy the criteria. Box 250 contains a representation of  
3 programs found in the EPG database 72. Suppose a viewer defined a science  
4 fiction (Sci-Fi) query using the advanced find window 240, as shown in Fig. 8, to  
5 locate Sci-Fi programs. The EPG application 164 executes the Sci-Fi query 252  
6 and winnows the program database to a short list of Sci-Fi programs, as presented  
7 in box 254. This short list of Sci-Fi programs is then presented in the UI as a  
8 closed loop list which can be cycled by the viewer for selection of a particular  
9 program.

10           Fig. 10 demonstrates a restrictive query which functions to filter out and  
11 remove programs which are prohibited under the query. In this example, the EPG  
12 applies a restrictive query filter 256 to the program set 250 in the EPG database  
13 which eliminates programs rated PG or R. The short list provided in box 258 is  
14 without PG or R rated programs.

15           Figs. 11 and 12 illustrate another aspect of this invention in which the EPG  
16 is configured to merge multiple queries into a unified query. Suppose, for  
17 example, that multiple members in a family want to watch a program together, but  
18 are not sure which program. Typically, each family member individually scans the  
19 program listings, or surfs the channels, to find one or two programs they are most  
20 interested in watching. After everyone is through with his or her independent  
21 search, they discuss about which program to watch. The EPG 164 eliminates this  
22 problem by creating complex composite queries which merge multiple simple  
23 single queries.

24           Fig. 11 shows an example UI window 260 having a folder organization  
25 which maintains queries for individual viewers. In this example, a family of

1 four—Dad, Mom, John, and Sue—each have their own tab and folder which lists  
2 their personalized queries. That is, each family member has previously defined  
3 one or more queries and stored them in their personal folder. The Mom folder  
4 holds queries for musical programs, programs on France, and the Seinfeld  
5 program. Table 1 shows the queries for all family members.

6  
7 Table 1: Family Queries

| <u>Family Member</u> | <u>Queries</u>             |
|----------------------|----------------------------|
| Dad                  | Sports, Comedies           |
| Mom                  | Musicals, France, Seinfeld |
| John                 | Star Trek, Action          |
| Sue                  | Cartoons, No R-rated       |

8  
9  
10  
11  
12  
13  
14 When the family sits down to watch a program together, one viewer can  
15 execute a merge query that effectively combines these independent queries using,  
16 for example, an OR function. The Boolean OR function returns a true result if any  
17 one of the parameter sets is met. In Fig. 12, a program set 262 is filtered using  
18 Dad's query filter(s) 264, Mom's query filter(s) 266, John's query filter(s) 268,  
19 and Sue's query filter(s) 270. The programs satisfying at least one of these queries  
20 is placed in the program pool 272, from which the family members can choose a  
21 program. It is noted that the family filter can be alternatively set to combine using  
22 a set intersect method or Boolean AND function which returns a program only if  
23 the query parameter sets of each family member is met.

24 Notice that some programs are listed because they satisfy a single query  
25 (e.g., US Open Golf is selected by Dad's query filter 264). Other programs may

1 satisfy more than one query. For example, the program "Seinfeld" satisfies Mom's  
2 Seinfeld query and Dad's comedies query. The animated movie "Aristocats"  
3 satisfies Mom's France query and Sue's cartoon query.

4 Fig. 13 illustrates the data flow for the programming data used by the EPG  
5 application, and how the query filters act to pare the data. Suppose that the viewer  
6 is watching the viewer computing unit 60 at 1:00 PM, as indicated by the clock  
7 280. Broadcast digital video and audio data, along with the digital programming  
8 data, are received from the satellite system at satellite receiver 50. The  
9 programming data is cached in the local EPG database 72. In this illustration, the  
10 EPG database is shown as having twelve programs with start times ranging from  
11 1:00 PM to 8:00 PM. This represents a tiny fraction of available programs, as the  
12 EPG database 72 can store thousands of programs that are available over hundreds  
13 to thousands of channels.

14 The viewer has defined a restrictive query 282 that removes all Sci-Fi  
15 programs from the active EPG UI 170. In this case, the programs "Star Trek,"  
16 "Aliens," and "Star Wars" are eliminated from the EPG UI 170. Now, suppose the  
17 viewer decides to watch CNBC Market Wrap at 1:00 PM. The viewer selects the  
18 program by highlighting and clicking on the Market Wrap program tile in the EPG  
19 UI 170. The tuner in the viewer computing unit tunes to the channel carrying the  
20 selected program and the digital video data for Market Wrap is sent to the VGA  
21 monitor.

22 According to another aspect of this invention, the viewer can define queries  
23 that continue to execute in background. The viewer defines the query to identify a  
24 topic of interest, such as any programs concerning the Great Wall of China or any  
25 programs starring Clint Eastwood. The query is stored and periodically executed

1 to determine if there are any programs which relate to the topic. When the query  
2 identifies a program related to the topic, the EPG automatically notifies the viewer.

3 Fig. 13 shows two queries that execute in background. The first query 284  
4 identifies and notifies the viewer of all "Seinfeld" programs and the second query  
5 286 identifies and notifies the viewer of all Clint Eastwood movies. When the  
6 viewer looks at the upcoming schedule for 2:00 PM, the EPG UI 288 shows all  
7 programs from the filtered version of the EPG UI 170 which show at 2:00 PM,  
8 such as the US Open Golf and Seinfeld. The EPG UI 288 also shows any  
9 programs identified by the background queries as a result of searching the EPG  
10 database 72. Here, the background queries 284 and 286 identified a Seinfeld  
11 program playing at 2:00 PM and a Clint Eastwood movie "Pale Rider" at 6:00 PM.  
12 Since there is a conflict at 2:00 PM, the viewer can choose between the Seinfeld  
13 program and the US Open Golf program.

14 Since the movie Pale Rider is not until 6:00 PM, the viewer can place a  
15 notification icon 290 on the screen to remind him/her of the program. The viewer  
16 clicks on the program, drags it from the EPG UI 288, and drops it at another  
17 location on the screen. The drag-and-drop operation results in creation of an  
18 instruction to tune the visual display unit to the program upon activation of the  
19 icon. The EPG can flash the icon, or cause some other visual change, when the  
20 start time of the program nears.

21 The EPG can also automatically create these reminders, without  
22 intervention of the viewer. When the EPG identifies a program, such as Pale Rider  
23 in response to the background query 286, the EPG can be configured to  
24 automatically set an icon 290 on the screen for the viewer. The viewer can also set  
25 an option for the EPG to initiate recording of the program in the event that the

1 viewer does not timely activate the icon prior to the scheduled viewing time. In  
2 this manner, if the viewer is unable to watch the program at the schedule time, the  
3 EPG intelligently queries the database for upcoming programs, identifies any  
4 programs that meet the viewer's search parameters, notifies the viewer, and  
5 records the program if the viewer is unable to watch it. There are other  
6 triggerable events that may be set based on the queries, such as automatically  
7 downloading information about the identified program, calling particular content  
8 from the Web, or launching a purchasing application to purchase goods related to  
9 the identified program.

10 This example illustrates concurrent use of multiple filters including  
11 personal background filters and an active general filter. The EPG can be  
12 configured to perform any number of queries, such as any restrictive queries for  
13 the logged on viewers, then any general queries, and then any background queries  
14 to filter the programs found in the EPG database to a manageable set of preferred  
15 programs.

16 Another aspect of this invention is to provide queries which filter  
17 information from the EPG database and from one or more Web sites on the  
18 Internet. The query results can be presented to the user in a single UI. The queries  
19 for the Web sites or other information on the Internet can be active queries that  
20 readily filter during online communication with the Internet, or queries that filter  
21 information in a local cache filled with Internet data.

22 Fig. 14 is similar to the arrangement of Fig. 13, but shows the effect of  
23 queries operating on both the EPG database and an Internet Web site. Fig. 14  
24 shows two queries, an EPG database query 282 which filters data in the EPG  
25 database 72 to remove all science fiction programs and a Web cache query 292

1 which filters a Web cache 294 to locate only news programs. The Web cache 294  
2 contains recently retrieved from one or more Web sites on the Internet.

3 The results of the two queries are displayed together on UI 296 to present a  
4 list of options to the viewer. The viewer can optionally select programs served by  
5 the content provider over the primary distribution network, or content served by  
6 the Internet provider over the Internet. By using an integrated UI 296, the viewer  
7 might be unaware as to the source of the content.

8 Fig. 15 shows a quick find window 300 supported by the EPG application  
9 164 which presents another technique for creating a query. This technique enables  
10 a viewer to enter data from a numeric keypad on the remote control handset. The  
11 numeric keypad is a conventional 0-9 digit keypad. Numbered keys 2-9 also have  
12 letters associated with them, similar to a conventional telephone, except the  
13 number "7" key includes the letter Q and the number "9" key includes the letter Z.  
14 Table 2 shows the association of the numbered keys and letters.

15  
16 Table 2: Association of Letters to Numbered Keypad

| <u>Key</u> | <u>Associated Letters</u> |
|------------|---------------------------|
| 1          |                           |
| 2          | A, B, C                   |
| 3          | D, E, F                   |
| 4          | G, H, I                   |
| 5          | J, K, L                   |
| 6          | M, N, O                   |
| 7          | P, Q, R, S                |
| 8          | T, U, V                   |

1 9

W, X, Y, Z

2 0

3  
4 Suppose a viewer wants to watch a particular program or network, but  
5 cannot remember what channel it is on. Remember, there are expected to be  
6 hundreds or thousands of channels, and trying to locate a particular program or  
7 network by memorizing each channel number may prove futile. To decouple the  
8 association of channel numbers to networks and programs, the EPG enables the  
9 viewer to enter data from the 10-key keypad for both channel numbers or letters in  
10 the program or network name. The EPG performs the mapping to identify any  
11 program, channel, or network that matches the entered data.

12 The quick find window 300 is activated by pressing one of the keys on the  
13 remote control handset. With quick find active, the viewer presses individual keys  
14 on the remote control handset to enter data, one digit at a time. As each key is  
15 depressed, however, the EPG does not know if the viewer intends to enter a  
16 number or a letter. Accordingly, for each key, the EPG constructs a query which  
17 interprets the data as possibly representing a number or one of the letters  
18 associated with the numeric key. The EPG then executes the query to identify any  
19 EPG data item (i.e., channel, program, network, etc.) that satisfies the query. As  
20 the viewer continues to enter digits, the EPG constructs and executes queries to  
21 continuously narrow the list until only a few EPG data items satisfy them.

22 With reference to the example shown in Fig. 15, suppose the viewer is  
23 interested in watching the Orlando Magic basketball team. The viewer activates  
24 the quick find window 300 and begins entering the word "Magic." The viewer  
25 first depresses the "6"-key, which has the associated letters M, N, and O, to enter

1 the letter "M" in "Magic." The EPG constructs a query for all EPG items  
2 beginning with the digit "6," "M," "N," or "O." In Boolean logic terms, the query  
3 is represented as follows:

4  
5 Query 1 = 6\* or M\* or N\* or O\*

6  
7 The symbol "\*" means that any digit or digits can follow the number or  
8 letter shown. The query returns a long list of items, including the following  
9 examples:

10  
11 Query 1: 6\* or M\* or N\* or O\*

12 MTV

13 Chicago Bulls at Orlando Magic

14 Seattle Mariners v. Boston Red Sox

15 Market Wrap

16 Magical World of Science

17 Magic Kingdom at Disney World

18 Orlando Magic v. Chicago Bulls

19 Nashville Live

20 NBC

21 Nick-at-Night

22 Outer Limits

23 Oprah

24 Channel 6

25 Channel 61



1  
2  
3  
4  
5  
6  
7  
8  
9  
10  
11  
12  
13  
14  
15  
16  
17  
18  
19  
20  
21  
22  
23  
24  
25

:  
:

The viewer next depresses the "2"-key, which has the associated letters A, B, and C, to enter the letter "a" in "Magic." The EPG constructs a query for all EPG items in the first list having a next digit beginning with "2," "A," "B," or "C." In Boolean logic terms, the query is represented as follows:

Query 2 = 62\* or MA\* or MB\* or MC\* or NA\* or NB\* or NC\*  
or OA\* or OB\* or OC\*

The query returns a shorter list of items, including the following examples:

Query 2

- Chicago Bulls at Orlando Magic
- Seattle Mariners v. Boston Red Sox
- Market Wrap
- Magical World of Science
- Magic Kingdom at Disney World
- Orlando Magic v. Chicago Bulls
- Nashville Live
- NBC
- Channel 62
- Channel 621

:  
:



1 An alternative technique to searching on each number or letter is to pre-map  
2 the program and network names into associated identification numbers which can  
3 be stored as part of the data record in the EPG database. For instance, the network  
4 name MTV has an associated identification number "688," where the letter "M" is  
5 mapped to the number "6," the letter "T" is mapped to the number "8," and the  
6 letter "V" is mapped to the number "8." With this pre-mapped identification  
7 number, the EPG can simply search on each numerical data and return all channel  
8 numbers, and all programs with identification numbers satisfying the query.

9 The quick find feature is very useful to the viewer. The viewer need not use  
10 the remote keyboard to enter names of programs or networks (although the  
11 keyboard may be used). Instead, the viewer enters the data using the 10-key  
12 keypad on the remote control handset and the EPG simultaneously considers all  
13 possible meanings of the data. Although this may seem laborious, entry of just a  
14 few digits (e.g., 3 to 6) is often sufficient to reduce the set of possible channel  
15 numbers, programs, and network names to only a few which can be conveniently  
16 displayed to the viewer.

17 The quick find feature is described above as performing a new set of  
18 queries after each digit is entered. However, the EPG can be alternatively  
19 configured to await entry of multiple digits before performing the queries. For  
20 instance, the EPG can keep track of the sequence of entered digits, and the various  
21 permutations of possible letter combinations within the sequence, and then  
22 subsequently perform queries on those possibilities.

23 It is noted that the above example describes the viewer as entering data  
24 using a keypad on the remote control handset. In other embodiments, the EPG is  
25 configured to present a keypad of soft buttons (i.e., buttons shown as part of the

1 graphical UI on the monitor) which the viewer can select using a handset or some  
2 other remote device to enter the data. Additionally, the viewer can enter channel  
3 numbers, program names, and network names using the remote keyboard.

4 It is noted that the term "program" is represented in examples as traditional  
5 television shows, or movies. The term "program" is not to be limited, however, to  
6 only these forms of programming. The term "program" is to be given a broad  
7 meaning, including any type of information or data that can be carried over a  
8 network or stored locally. Examples of "programs" include TV-like shows,  
9 movies, games, interactive supplemental data, financial records or programs,  
10 educational materials, communications records, software, document files, and the  
11 like.

12 The query-base EPG system described herein is advantageous because it  
13 effectively decouples the association of channel from network and programs. The  
14 viewer can create simple queries to search on prearranged categories or complex  
15 queries to search across arbitrary fields. The EPG permits viewers to merge their  
16 individual queries into a composite query, which offers tremendous convenience  
17 for groups of viewers. The EPG also permits a viewer to save queries in a  
18 convenient hierarchic structure. The saved queries can also be loaded into a start  
19 menu for execution each time the viewer boots the viewer computing unit.

20 The invention has been described in language more or less specific as to  
21 structural and methodical features. It is to be understood, however, that the  
22 invention is not limited to the specific features described, since the means herein  
23 disclosed comprise preferred forms of putting the invention into effect. The  
24 invention is, therefore, claimed in any of its forms or modifications within the  
25

1 proper scope of the appended claims appropriately interpreted in accordance with  
2 the doctrine of equivalents.  
3  
4  
5  
6  
7  
8  
9  
10  
11  
12  
13  
14  
15  
16  
17  
18  
19  
20  
21  
22  
23  
24  
25

1 **CLAIMS**

2           1. A method for operating an electronic program guide comprising the  
3 following steps:

4                 collecting viewing preferences of a viewer; and

5                 developing a query for identifying programs based upon the viewing  
6 preferences of the viewer.

7  
8           2. A method as recited in claim 1, wherein the collecting step comprises  
9 the step of monitoring viewing habits of the viewer as an indication of the viewing  
10 preferences.

11  
12           3. A method as recited in claim 1, wherein the collecting step comprises  
13 the following steps:

14                 creating a viewer profile of the viewer; and

15                 correlating the viewer profile with other viewer profiles to infer the viewing  
16 preferences of the viewer.

17  
18           4. A method as recited in claim 1, further comprising the step of  
19 presenting, to the viewer, a list of programs identified by the query.

20  
21           5. A method as recited in claim 4, further comprising the step of  
22 ordering the list of programs to group programs which the viewer is more likely to  
23 watch in one part of the list and programs which the viewer is less likely to watch  
24 in another part of the list.

25

1           6.    A method as recited in claim 1, wherein the collecting step comprises  
2 the following steps:

3           conducting the query; and

4           assembling the programs identified by the query as a viewer program set  
5 through which the viewer can sequentially cycle.

6  
7           7.    A method as recited in claim 1, further comprising the step of saving  
8 the query in a hierarchic query structure.

9  
10          8.    An electronic program guide resident in a computer-readable storage  
11 medium and executable on a processor to perform the steps of the method recited  
12 in claim 1.

13  
14          9.    A viewer computing unit programmed to perform the steps of the  
15 method recited in claim 1.

16  
17          10.   A computer-readable storage medium which directs a computer to  
18 perform the steps of the method recited in claim 1.

19  
20          11.   A method for operating an electronic program guide comprising the  
21 following steps:

22           logging an amount of time that a particular channel is selected for viewing;

23 and

24           generating a query to identify channels based upon a percentage of the time  
25 that the channels are selected.

1  
2  
3  
4  
5  
6  
7  
8  
9  
10  
11  
12  
13  
14  
15  
16  
17  
18  
19  
20  
21  
22  
23  
24  
25

**12.** A method as recited in claim 11, further comprising the following steps:  
presenting, to the viewer, a list of the channels identified by the query; and  
ordering the channels within the list according to the percentage of time that the channels are selected for viewing so that channels which are selected a higher percentage of the time appear at one place in the list and channels which are selected a lower percentage of the time appear at another place in the list.

**13.** A method as recited in claim 11, further comprising the step of generating a query to identify channels which have been selected at least a threshold amount of time to eliminate rarely selected channels from identification.

**14.** A method as recited in claim 11, further comprising the step of saving the query in a hierarchic query structure.

**15.** An electronic program guide resident in a computer-readable storage medium and executable on a processor to perform the steps of the method recited in claim 11.

**16.** A viewer computing unit programmed to perform the steps of the method recited in claim 11.



1           **17.**    A computer-readable storage medium which directs a computer to  
2 perform the steps of the method recited in claim 11.

3  
4           **18.**    A method for operating an electronic program guide comprising the  
5 following steps:

6            defining a first query for identifying programs preferred by a first viewer;

7            defining a second query for identifying programs preferred by a second  
8 viewer; and

9            creating a unified query which combines the first and second queries to  
10 jointly identify the programs preferred by at least one of the first and second  
11 viewers.

12  
13           **19.**    A method as recited in claim 18, wherein the creating step comprises  
14 the step of combining the first and second queries according to a logical OR  
15 function.

16  
17           **20.**    A method as recited in claim 18, further comprising the following  
18 steps:

19            conducting a search of programs available on the electronic program guide  
20 using the unified query; and

21            presenting the programs that satisfy the unified query.  
22  
23  
24  
25

1           **21.**    A method as recited in claim 18, further comprising the step of  
2 automatically generating at least one of the first and second queries based upon  
3 viewing preferences of the respective first and second viewers.

4  
5           **22.**    A method as recited in claim 18, further comprising the step of  
6 saving the queries in a hierarchic query structure.

7  
8           **23.**    An electronic program guide resident in a computer-readable storage  
9 medium and executable on a processor to perform the steps of the method recited  
10 in claim 18.

11  
12           **24.**    A viewer computing unit programmed to perform the steps of the  
13 method recited in claim 18.

14  
15           **25.**    A computer-readable storage medium which directs a computer to  
16 perform the steps of the method recited in claim 18.

17  
18           **26.**    A method for operating an electronic program guide (EPG)  
19 comprising the following steps:

20           defining a first query for identifying selected programs in an EPG database;

21           defining a second query for identifying selected programs retrievable from a  
22 site on the Internet; and

23           creating a unified query which combines the first and second queries to  
24 jointly identify the selected programs.

25

1           27.    A method as recited in claim 26, further comprising the step of  
2 saving the queries in a hierarchic query structure.

3  
4           28.    An electronic program guide resident in a computer-readable storage  
5 medium and executable on a processor to perform the steps of the method recited  
6 in claim 26.

7  
8           29.    A viewer computing unit programmed to perform the steps of the  
9 method recited in claim 26.

10  
11          30.    A computer-readable storage medium which directs a computer to  
12 perform the steps of the method recited in claim 26.

13  
14          31.    A method for operating an electronic program guide comprising the  
15 following steps:

16            defining a query to identify a topic of interest to a viewer;

17            storing the query;

18            periodically executing the query to determine if there are any programs  
19 which relate to the topic; and

20            automatically notifying the viewer when the query identifies a program  
21 related to the topic.

22  
23          32.    A method as recited in claim 31, further comprising the step of  
24 automatically initiating procedures to record the program related to the topic.

25

1           **33.**    A method as recited in claim 31, further comprising the step of  
2 saving the query in a hierarchic query structure.

3  
4           **34.**    An electronic program guide resident in a computer-readable storage  
5 medium and executable on a processor to perform the steps of the method recited  
6 in claim 31.

7  
8           **35.**    A viewer computing unit programmed to perform the steps of the  
9 method recited in claim 31.

10  
11          **36.**    A computer-readable storage medium which directs a computer to  
12 perform the steps of the method recited in claim 31.

13  
14          **37.**    A method for operating an electronic program guide (EPG) as a  
15 viewer uses one or more numeric keys to enter data, individual ones of the keys  
16 also corresponding to one or more associated letters, comprising the following  
17 steps:

18            constructing a query, based on the entered data, which considers that the  
19 entered data might represent a number or a letter associated with the numeric key  
20 used to enter the data; and

21            identifying any EPG data item that satisfies the query.

22  
23          **38.**    A method as recited in claim 37, further comprising the additional  
24 step of repeating the steps of constructing and identifying for each key entry.

25

1           **39.**    A method as recited in claim 37, wherein the steps of constructing  
2 and identifying are performed after multiple key entries.

3  
4           **40.**    A method as recited in claim 37, further comprising the additional  
5 step of presenting, to the viewer, said any EPG data item which satisfies the query.

6  
7           **41.**    A method as recited in claim 37, wherein the constructing step  
8 comprises the following steps:

9                formulating one or more letter sub-queries for each letter corresponding to  
10 the key used for entry;

11               formulating a number sub-query for each number corresponding to the key  
12 used for entry; and

13               formulating the query as a combination of the letter and number sub-  
14 queries.

15  
16           **42.**    A method as recited in claim 37, wherein the data is a result of more  
17 than one key entry, and the constructing step further comprises the following steps:

18                interpreting the data for each key entry as representing both the number and  
19 the associated letters corresponding to the key;

20                formulating multiple sub-queries for each sequence of key entries which  
21 considers different interpretations of the data within the sequence; and

22                formulating a composite query as a combination of all the sub-queries.  
23  
24  
25

1           **43.**    An electronic program guide resident in a computer-readable storage  
2 medium and executable on a processor to perform the steps of the method recited  
3 in claim 37.

4  
5           **44.**    A viewer computing unit programmed to perform the steps of the  
6 method recited in claim 37.

7  
8           **45.**    A computer-readable storage medium which directs a computer to  
9 perform the steps of the method recited in claim 37.

10  
11           **46.**    In a viewing computing unit which can be controlled through a  
12 numeric keypad having numbered keys, the keys further corresponding to one or  
13 more associated letters, a method comprising the following steps:

14               generating key data as a key is activated;

15               interpreting the key data as representing both a number associated with the  
16 key and the one or more letters associated with the key; and

17               determining possible operations which can be performed by the viewer  
18 computing unit for different interpretations of the key data.

19  
20  
21  
22  
23  
24  
25

1           47.    A method as recited in claim 46, wherein the numbers are used to  
2 identify a channel and the letters are used to identify a program or network name,  
3 the method further comprising the step of mapping the one or more letters  
4 associated with the key to the number associated with the key so that the channels,  
5 the program names, and the network names are all identified by numerically  
6 encoded key data.

7  
8           48.    A method as recited in claim 46, further comprising the additional  
9 step of repeating the steps of generating, interpreting, and identifying as each key  
10 is activated.

11  
12           49.    A method as recited in claim 46, wherein the interpreting and  
13 determining steps are performed only after the step of generating key data has been  
14 performed for all activated keys.

15  
16           50.    A method as recited in claim 46, wherein the interpreting step  
17 comprises the following steps:

18                formulating one or more letter sub-queries for each of the one or more  
19 letters associated with the key;

20                formulating a number sub-query for the number associated with the key;  
21 and

22                formulating a composite query as a combination of the letter and number  
23 sub-queries.

1           **51.**    A method as recited in claim 46, wherein more than one key is  
2 activated, further comprising the following steps:

3                   generating a sequence of key data;

4                   formulating multiple sub-queries for the sequence of key data which  
5 considers the different interpretations of the key data within the sequence; and

6                   formulating a composite query as a combination of all the sub-queries.  
7

8           **52.**    A method as recited in claim 46, further comprising the step of  
9 saving the query in a hierarchic query structure.  
10

11          **53.**    A viewer computing unit programmed to perform the steps of the  
12 method recited in claim 46.  
13

14          **54.**    A computer-readable storage medium which directs a computer to  
15 perform the steps of the method recited in claim 46.  
16

17          **55.**    A method for operating an electronic program guide comprising the  
18 following steps:

19                   creating a restriction query having one or more search parameters; and

20                   precluding selection of any program, channel, or network which satisfies  
21 the search parameters in the restriction query.  
22  
23  
24  
25



1           **56.**    A method as recited in claim 55, wherein the search parameters are  
2 selected from a parameter group comprising genre, sub-genre, rating, time of day,  
3 and length of time watched.

4  
5           **57.**    A method as recited in claim 55, further comprising the step of  
6 saving the query in a hierarchic query structure.

7  
8           **58.**    A method as recited in claim 55, further comprising the step of  
9 saving the query as an icon.

10  
11          **59.**    An electronic program guide resident in a computer-readable storage  
12 medium and executable on a processor to perform the steps of the method recited  
13 in claim 55.

14  
15          **60.**    A viewer computing unit programmed to perform the steps of the  
16 method recited in claim 55.

17  
18          **61.**    A computer-readable storage medium which directs a computer to  
19 perform the steps of the method recited in claim 55.

20  
21          **62.**    A method for operating an electronic program guide comprising the  
22 following steps:

23            creating queries for locating a program, channel, or network; and

24            saving the queries in a hierarchic query structure.

25

1           **63.**    A method as recited in claim 62, wherein the saving step comprises  
2 saving the queries as icons.

3  
4           **64.**    A method as recited in claim 62, further comprising presenting, to a  
5 viewer, a organization chart representing the hierarchic query structure.

6  
7           **65.**    A method as recited in claim 62, further comprising retrieving a  
8 query from the hierarchic query structure.

9  
10          **66.**    An electronic program guide resident in a computer-readable storage  
11 medium and executable on a processor to perform the steps of the method recited  
12 in claim 62.

13  
14          **67.**    A viewer computing unit programmed to perform the steps of the  
15 method recited in claim 62.

16  
17          **68.**    A computer-readable storage medium which directs a computer to  
18 perform the steps of the method recited in claim 62.

19  
20          **69.**    A computer-readable storage medium having a hierarchic query  
21 structure stored therein which is formed as a result of the steps of the method  
22 recited in claim 62.

23  
24          **70.**    A viewer computing unit, comprising:  
25 a processor; and

1 an electronic program guide (EPG) executing on the processor to organize  
2 programming information descriptive of programs, the EPG being configured to  
3 collect viewing preferences of a viewer and to automatically develop a query for  
4 identifying programming information based upon the viewing preferences of the  
5 viewer.

6  
7 71. A viewer computing unit as recited in claim 70, further comprising a  
8 memory to store a profile of the viewer which indicates the viewer's  
9 characteristics, the EPG being configured to automatically develop the query based  
10 on the viewer profile.

11  
12 72. A viewer computing unit as recited in claim 70, further comprising:  
13 a memory; and  
14 the EPG being configured to log the viewer's viewing habits in the memory  
15 and to automatically develop the query based on the viewing habits.

16  
17 73. A viewer computing unit as recited in claim 70, further comprising:  
18 a memory; and  
19 the EPG being configured to store the query in the memory within an  
20 organized, hierarchic structure.

1           **74.** For execution on a processor of a viewer computing unit, an  
2 electronic program guide (EPG) executing on the processor to organize  
3 programming information, the EPG being configured to enable multiple viewers to  
4 create queries for locating particular programming information, the EPG further  
5 creating a composite query that combines the queries of the viewers.  
6

7           **75.** For execution on a processor of a viewer computing unit, the viewer  
8 computing unit having a display, an electronic program guide (EPG) executing on  
9 the processor to organize programming information, the EPG supporting a  
10 graphical user interface which can be shown on the display and being configured  
11 to periodically and automatically execute a query and to present on the user  
12 interface a notification when the query is successful.  
13

14           **76.** An electronic programming guide as recited in claim 75, wherein  
15 while the display is showing a program, the EPG is configured to execute the  
16 query in background without interruption of the program.  
17  
18  
19  
20  
21  
22  
23  
24  
25

1           77. For execution on a processor of a viewer computing unit, wherein  
2 the viewer computing unit has numbered keys which additionally correspond to  
3 one or more associated letters, each key generating key data when a viewer  
4 activates the key to request programming information, an electronic program guide  
5 (EPG) executing on the processor to organize programming information, the EPG  
6 being configured to interpret the key data as representing both a number associated  
7 with the key and one or more letters associated with the key, the EPG being further  
8 configured to determine possible programming information that the viewer is  
9 likely to be requesting based on different interpretations of the key data.  
10  
11  
12  
13  
14  
15  
16  
17  
18  
19  
20  
21  
22  
23  
24  
25



Application No: GB 9805687.2  
Claims searched: 1-10,70-73

Examiner: K. Sylvan  
Date of search: 7 September 1998

**Patents Act 1977**  
**Search Report under Section 17**

**Databases searched:**

UK Patent Office collections, including GB, EP, WO & US patent specifications, in:

UK Cl (Ed.P): G4A (AUDB) H4F (FBB)

Int Cl (Ed.6): H04N (7/088) G06F (17/30)

Other: Online: WPI

**Documents considered to be relevant:**

| Category | Identity of document and relevant passage   | Relevant to claims |
|----------|---|--------------------|
| X        | EP0705036 A2 Sony. See the figures and column 3 lines 44-53.  | 1,4,6,9,70         |
| X        | EP0758833 A2 General Instrument Corporation of Delaware. See page 14 lines 2-5.   | 1,9,70             |
| X,P      | WO97/46011 A1 Sanyo. See the abstract.  | 1,9,70             |
| X        | WO97/02702 A2 Philips. See page 1 lines 17-23, page 2 lines 17-22, and page 17 lines 17-23.   | 1,4,6,8-10,70      |
| X        | WO94/14284 A1 Discovery Communications.<br>See the figures, page 40 lines 6-10, page 51 lines 24-25, page 59 lines 11-23, page 60 lines 13-15, page 60 line 29 to page 61 line 2, page 66 lines 4-13, page 68 lines 5-12 and 22-25, page 70 lines 3-13 and page 78 lines 25-30. | 1,2,4,5,6,9,70-72  |
| X        | US5606691 Harman Interactive. See column 4 lines 33-46 and column 2 lines 34-36.  | 1,4,6,8-10,70      |
| X        | US5223924 North American Philips. See column 4 line 59 to column 5 line 47.   | 1,2,9,70           |

X Document indicating lack of novelty or inventive step  
Y Document indicating lack of inventive step if combined with one or more other documents of same category.

A Document indicating technological background and/or state of the art.  
P Document published on or after the declared priority date but before the filing date of this invention.

E Patent document published on or after, but with priority date earlier than, the filing date of this application.

& Member of the same patent family